

16 Neurobiophysics

Oleg V. Kolomytkin and Andrew A. Marino

16.1	Introduction	525
16.2	Ion Channels	526
16.2.1	Overview	526
16.2.2	Na ⁺ Channels	528
16.2.3	K ⁺ Channels	529
16.2.4	Ca ²⁺ Channels	529
16.2.5	Cl ⁻ Channels	530
16.2.6	Ligand-Gated Channels	530
16.3	Biophysics of Neurons	531
16.3.1	Resting Membrane Potential	531
16.3.2	Chemical-to-Electrical Transduction	533
16.3.3	Signal Summation	534
16.3.4	Action Potential	537
16.3.5	Electrical-to-Chemical Transduction	539
16.4	Neuronal Systems	541
16.4.1	Overview	541
16.4.2	Sensory Systems	541
16.4.3	Neural Networks	544
16.4.4	Volume Transmission	545
16.4.5	Brain Electrical Activity	547
16.4.6	Learning and Memory	548
16.4.7	A Nonlinear Future	551
	Glossary	552
	References	554
	Further Reading	555

16.1

Introduction

Neurobiophysics is the study of the structure and function of the nervous system from the perspective of physics. In 1902, Julius Bernstein hypothesized that cells were ionic solutions surrounded by thin membranes having permeability properties that resulted in the establishment of an electrical potential across the membrane, and that during nervous system activity, the potential decreased as a result of changes in the permeability. These ideas led to the work of Alan Hodgkin and Andrew Huxley, which is presently recognized as the prototypical physical explanation of electrical conduction in nerve cells. Attempts to understand the nervous system were also made from other scientific perspectives including neuroanatomy, neurophysiology, neurochemistry, and molecular biology. The distinctions between the various areas of neuroscience are often difficult to discern, but for our purposes studies that emphasize the role of physical laws, elucidation of physical mechanisms, and the use of mathematical analysis are within neurobiophysics and will be considered here.

The basic structural and functional unit of the nervous system is the *neuron*,

which is a cell specialized to receive information and influence other neurons or effector cells (Figure 16.1). The complexity of the nervous system varies with the degree of evolutionary development of the organism; in mammals, the system is composed of more than 10^{11} neurons and perhaps 10 times that number of support cells (the neuroglia). There are many different kinds of neurons, but they can be classified into a small number of groups on the basis of common properties.

Information enters a neuron through an elaborate network of processes called *dendrites* and exits through a single process, the *axon*. Neurons communicate with one another by means of specialized contacts called *synapses*. A typical neuron simultaneously receives numerous signals at synapses on the dendrites or cell body. Each signal produces a decrease (excitatory) or increase (inhibitory) in the local *resting membrane potential* that propagates passively to the cell's trigger zone, usually the axon *hillock*. The contribution of a particular input decreases exponentially with increasing distance between its location and the hillock, and the cell responds to the instantaneous sum of the individual contributions. If the net change in the *membrane potential* at the

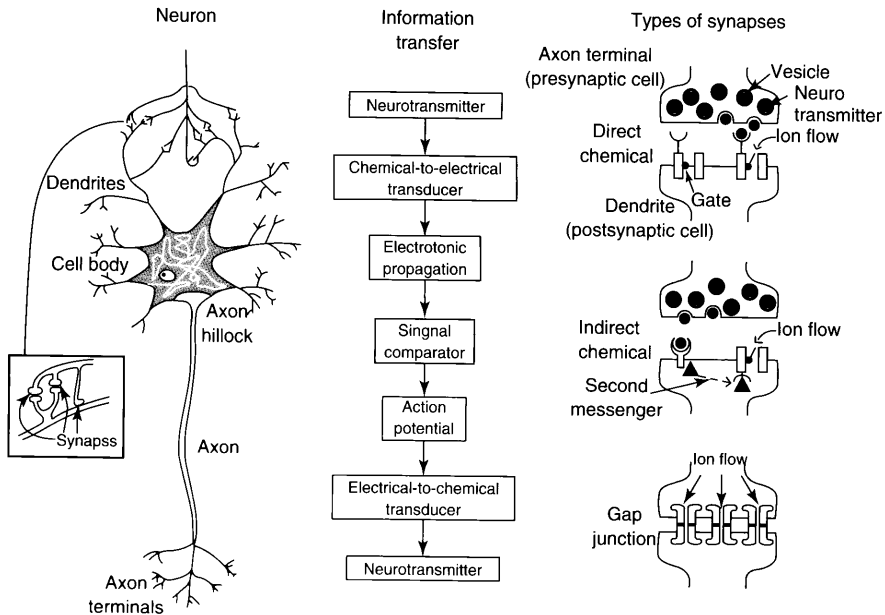

Fig. 16.1 Information transfer in the neuron. The presynaptic and postsynaptic neurons are defined by the direction of information transfer between them. In a chemical synapse, the cells are separated by a narrow gap across which a neurotransmitter diffuses and binds to receptors on the postsynaptic cell. The binding triggers the opening of membrane channels, allowing ions to pass from the interstitial fluid into the postsynaptic cell. In the direct chemical synapse, the receptor, membrane pore, and gate consist of a unitary protein complex. Alternatively, the receptor and channel may be physically separated but linked by intermediary second messengers (indirect chemical synapse). In gap junction synapses, ions pass between the cytoplasm of adjacent cells; gap junction channel conductance is relatively large (100–200 pS) compared with that of the channels at chemical synapses. Typically, directly gated channels mediate neuronal activity and indirectly gated channels modulate the excitability of neurons.

hillock induced by the summed inputs is a depolarization that exceeds a threshold value, an *action potential* (spike pulse) is generated and propagates along the axon. When the action potential arrives at the axon terminal, voltage-sensitive Ca^{2+} ion channels are activated thereby triggering release of neurotransmitters into the synaptic cleft.

Prior to discussing the action potential, we will describe the structure and function of ion channels. Thereafter, we will consider the dynamical properties of systems of neurons.

16.2 Ion Channels

16.2.1 Overview

The neuronal membrane is an electrically insulating phospholipid bilayer about 5 nm thick; the electrical activity of the neuron arises from the flow of ions through ion channels embedded in the membrane. A gated ion channel is a functional unit containing a pore through which ions may pass, a gate, and

a sensor capable of opening or closing the gate in response to a signal. There are two classes of gated ion channels, depending on the nature of the signal to which they are responsive. *Voltage-gated* channels have an ion conductance that depends on the cell's membrane potential, which provides the driving force for the ions and also affects the probability that the channel is open. The conductance of *ligand-gated channels* is directly or indirectly dependent on the binding of a neurotransmitter to the sensor portion of an ion channel or to a membrane receptor protein, respectively (Figure 16.1). Most gated channels exhibit only one of the two forms of gating behavior. Nongated channels are essentially membrane pores lacking gates and sensors.

The *selectivity* of a channel refers to the ion species that will pass through its pore. Voltage-gated channels are denoted by the ion that passes through most readily; the main types are Na^+ , K^+ , Ca^{2+} , Cl^- , and an ion channel that allows all small cations to pass (called a nonselective cation channel). Ligand-gated channels are labeled by the ligand that opens the channel. As examples, a Na^+ channel has Na^+ as the main permeant ion and a nicotinic acetylcholine channel is a transmembrane protein having a receptor capable of binding the neurotransmitter acetylcholine, which results in the passage of ions through the channel pore. The response of a neuron to its environment is mainly determined by the gating and selection characteristics of its ion channels, and by the density and distribution of each channel type in the neuronal membrane. Neurons contain: (i) nongated channels that

serve to establish the membrane potential; (ii) ligand-gated channels that subserve reception of the input signal; (iii) voltage-gated Na^+ and K^+ channels that function in a synchronized fashion to permit propagation of an action potential; (iv) voltage-gated Ca^{2+} channels that participate in the transduction of the action potential into the chemical signal that constitutes the neuron's output; (v) *gap junction* channels; and (vi) channels that are sensitive to various intracellular chemical signals.

Studies involving *site-directed mutagenesis* and X-ray crystallography have revealed some of the basic structural features of ion channels, for example the location of the ion-selective filter for voltage-gated Na^+ , Ca^{2+} , and K^+ channels (Gouaux and Mackinnon, 2005). The filter consists of negatively charged amino-acid residues and lies in the channel's pore-lining region (P segments). By changing specific amino acids in the P segments, the permeant-ion profile of Na^+ and Ca^{2+} channels can be interchanged. The primary structures of K^+ channels are more heterogeneous, but location of the selectivity filter has been narrowed down to a three-amino-acid motif in the P segment.

All known voltage-gated channels sense voltage changes by means of a protein subunit called the S4 segment, which was identified on the basis of measurements of the *gating current*. A span of at least seven S4 amino acids is exposed extracellularly during activation of K^+ channels, suggesting that either the S4 amino acids moved extracellularly or the rest of the channel protein moved intracellularly. A typical gating current consists of the movement of 10 positive charges through a distance up to 0.3 nm.

Gap junctions are ion channels that connect the cytoplasm of adjacent cells, thereby allowing passage of ions and signaling molecules smaller than ≈ 1 kDa. Transmembrane protein subunits called *connexins* form a pore that constitutes one half of the gap junction; the other half is formed by a similar structure on an adjacent cell. Heterology among the connexin subunits allows differences in permeability, conductance, and gating of gap junctions by voltage or various ligands (Hervé *et al.*, 2007).

16.2.2

Na^+ Channels

Na^+ channels respond rapidly to depolarization; their basic role in the nervous system is to generate the initial portion of the action potential. Nine members of the voltage-gated sodium-channel family are known (Benarroch, 2007); their amino-acid identity is greater than 50%.

A Na^+ channel consists of one α and 1–4 β protein subunits (Figure 16.2); the α subunit determines the channel's selective and gating properties that are

modulated by the β subunits. An α subunit has four homologous domains (I–IV) that each contains six hydrophobic amino-acid sequences (S1–S6) arranged to form a pore selective for the passage of Na^+ . The channel's voltage sensitivity is located in S4, a highly conserved amino-acid sequence composed of positively charged amino acids. During depolarization, the S4 region moves toward the outer side of the membrane thereby allowing the channel to conduct ions. The selectivity filter, the narrowest part of the pore (0.3×0.5 nm), is formed by the extracellular region between S5 and S6 (P-loops) of all four domains; the filter permits single Na^+ and associated water molecules to pass, but excludes the larger K^+ , negatively charged glutamic acid residues, and Cl^- .

Three states of voltage-gated Na^+ channels have been identified: deactivated, activated, and inactivated; the channel is open only in the activated state. Transitions between states can be described as a Markovian process or by the Hodgkin–Huxley formalism (see below).

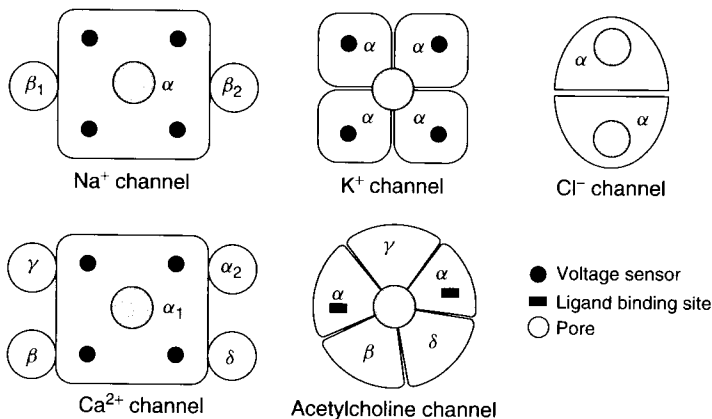

Fig. 16.2 Subunit composition of ion channels (depicted from above the plasma membrane).

16.2.3 K⁺ Channels

The K⁺ family of voltage-gated ion channels is the largest and most diverse group of voltage-gated ion channels (Doyle *et al.*, 1998). K⁺ channels subserve many functions, including return of the membrane potential to its preexisting level, formation of trains of action potentials, and the occurrence of rhythmic activity. There are at least four major classes of voltage-gated K⁺ channels in the nervous system, and perhaps 10 times that number of K⁺ channel subtypes. The main class is the *delayed rectifier*, which is the axonal K⁺ channel that opens with depolarization and is largely responsible for repolarizing the axon membrane following an action potential. Other important types of K⁺ channels include (i) an axonal channel that opens rapidly upon depolarization and then quickly closes; (ii) an inward-rectifying channel that opens only with hyperpolarization; and (iii) a channel that is sensitive to intracellular Ca²⁺. In the case of the Ca²⁺-sensitive K⁺ channel, the Ca²⁺ concentration shifts the channel voltage dependence (Hille, 1992). There is only about a 10% variation in the total amino-acid sequence among the various K⁺ channels.

The molecular mass of the K⁺ channel protein is about 25% of that of the Na⁺ channel protein, and consists of six transmembrane segments. By analogy with the known structure of the Na⁺ channel, a K⁺ channel is thought to be a tetramer with a central pore (Figure 16.2). Five residues from each subunit form the selectivity filter; their negatively charged carbonyl oxygen atoms are directed toward the pore and interact with the K⁺, effectively replacing

its hydration shell; the Na⁺ does not penetrate the filter because the ion's interaction with its hydration shell is greater than with the carbonyl oxygen atoms in the pore.

The conductance of some K⁺ channels appears to exceed the value associated with movement of K⁺ in aqueous solutions. One possibility is that the channel can accommodate more than one ion at a time. If so, the presence of the first ion might reduce the electrostatic forces on the second ion, thereby facilitating its passage through the pore.

Axons from mollusks, arthropods, annelids, and vertebrates contain essentially identical Na⁺ channels and K⁺ channels, indicating that the evolution of these channels was essentially complete at the time of the common ancestor of these phyla, approximately 500 million years ago.

16.2.4 Ca²⁺ Channels

There are many types of voltage-gated Ca²⁺ channels in the nervous system, including types N, L, P, Q, R, and T. They all open with depolarization and appear to have a common subunit composition (Figure 16.2), but differ in voltage dependence, ionic selectivity, and pharmacology. The α subunit forms the Ca²⁺-selective pore and contains the voltage-sensing machinery or ligand-binding sites. The subunit consists of four homologous domains (I–IV), each containing six transmembrane α -helices; the α_1 subunit (190 kDa) determines most of the channel's properties; there are at least four variations of α_1 . The α_2 , β , γ , and δ subunits modulate the properties of the Ca²⁺ channel.

Neurotransmitter secretion at nerve terminals is a well-studied Ca^{2+} -dependent process. N-type voltage-gated Ca^{2+} channels in the presynaptic terminal open in response to the depolarization produced by the arrival of the action potential, thereby triggering membrane-bound vesicles containing neurotransmitter to fuse with the axon membrane, resulting in release of the neurotransmitter into the synapse. The Ca^{2+} channels in the axon terminal provide the only mechanism whereby the action potential can be transduced into a form capable of carrying information across a chemical synapse.

16.2.5

Cl^- Channels

The superfamily of Cl^- channels consists of approximately 13 members; factors that can regulate Cl^- channel activity include voltage, Ca^{2+} concentration, extracellular ligands, and pH (Suzuki, Morita and Iwamoto, 2006). Chloride channels are important for maintaining resting membrane potential and normal cell volume; they conduct Cl^- as well as other small anions including HCO_3^- , I^- , SCN^- , and NO_3^- . Chloride channel subunits are between 1 and 12 transmembrane segments.

16.2.6

Ligand-Gated Channels

Ligand-gated ion channels are specialized for converting neurotransmitters (Table 16.1) into graded electrical signals; the similarity in structure of ligand-gated channels suggests that they are a protein superfamily. The channels open transiently following binding of a neurotransmitter, thereby producing a

Tab. 16.1 Neurotransmitters organized by chemical properties.

Monoamines and Acetylcholine

Acetylcholine
Dopamine
Epinephrine
Histamine
Norepinephrine
Serotonin

Amino Acids

Aspartate
Gamma aminobutyric acid
Glutamate
Glycine
Serine

Purines

Adenosine
Adenosine triphosphate

Gases

Carbon monoxide
Nitric oxide

Lipids

2-arachidonoylglycerol
Anandamide

Peptides

Beta-endorphin
Bombesin
Bradykinin
Corticotrophin releasing hormone
Galanin
Neuropeptide Y
Neurotensin
Orexin
Oxytocin
Peptide YY
Somatostatin
Substance P
Vasoactive intestinal polypeptide
Vasopressin

postsynaptic potential as a consequence of the ion flux; ligand-gated channels are usually voltage insensitive. In one type of ligand-gated channels, the receptor, membrane pore, and gate consist of a unitary protein structure (*direct chemical synapse*); in another type (*indirect chemical synapse*) the receptor and pore

portions of the channel are physically separated but linked by intermediary substances known as second (or higher-order) messengers (Figure 16.1). Ligand-gated channels have one or more binding sites for a particular neurotransmitter or second messenger, and a characteristic ion selectivity.

The most studied ligand-gated channel is the nicotinic acetylcholine receptor (nAChR) channel (Figure 16.2), which is found at the neuromuscular junction and at other locations in the nervous system; the nAChR serves as a prototype for the less studied ligand-gated channels. The receptor molecule is ~9 nm in diameter, and protrudes from the membrane surfaces ~6 nm into the extracellular space and ~2 nm into the cytosol. When two acetylcholine molecules bind to the receptor, a conformational change occurs that opens an aqueous pore 2–3 nm in diameter for about a millisecond; thereafter the molecules disassociate from the receptor and are hydrolyzed by acetylcholinesterase. The nAChR excludes anions, possibly because of the negatively charged amino acids at its mouth. The channel is formed from five subunits (stoichiometry shown in Figure 16.2); the α subunits bind acetylcholine with high affinity, one molecule of which must bind to each α subunit for the channel to open efficiently. Site-directed mutagenesis of the cDNAs of the α subunits has shown that the binding sites for acetylcholine are located near two cysteine residues on the extracellular portion of the subunit. The four subunits are encoded by different but homologous genes; each subunit appears to consist of four membrane-spanning regions arranged in such a way that specific regions of each of the subunits face each other to create the membrane-spanning pore.

16.3 Biophysics of Neurons

16.3.1

Resting Membrane Potential

The membrane potential of the neuron E_m is established by the same mechanism as in other cells (Figure 16.3). The Na^+/K^+ pump, a transmembrane energy-consuming enzyme, moves three Na^+ out of the cell and two K^+ in for each molecule of adenosine triphosphate converted to adenosine diphosphate. Nongated ion channels permit passive transmembrane flow of ions down their electrochemical potential gradients, principally Na^+ and K^+ .

E_m is given by the Goldman–Hodgkin–Katz (GHK) equation (Hille, 1992):

$$E_m = \frac{RT}{F} \ln \frac{P_{\text{Na}}[\text{Na}^+]_o + P_{\text{K}}[\text{K}^+]_o + P_{\text{Cl}}[\text{Cl}^-]_i}{P_{\text{Na}}[\text{Na}^+]_i + P_{\text{K}}[\text{K}^+]_i + P_{\text{Cl}}[\text{Cl}^-]_o} \quad (1)$$

where R is the universal gas constant, T is the absolute temperature, F is Faraday's constant, the internal and external concentrations of Na^+ are, respectively, represented by $[\text{Na}^+]_i$ and $[\text{Na}^+]_o$, P_{Na} is the membrane permeability for Na^+ ions, and the concentrations and permeabilities of K^+ and Cl^- are defined similarly. If the permeability of any two of the ions is zero, the GHK equation reduces to the Nernst equation for the third ion and the resulting potential is the *reversal potential* for that ion. In the resting state, the cell membrane is more permeable to K^+ than to Na^+ and Cl^- ; consequently the resting potential is close to the K^+ reversal

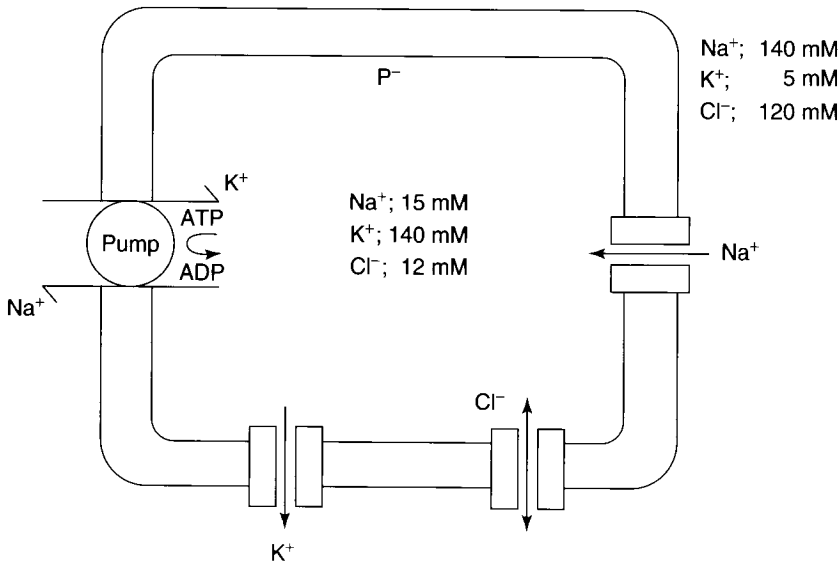

Fig. 16.3 The pump-leak model for the origin of the cell resting membrane potential. The interaction among the pump and leak channels results in a negative membrane potential (cell interior with respect to exterior). P^- , negatively charged impermeant proteins. Typical intracellular and extracellular concentrations of several important ions are shown.

potential, typically -65 mV (cell interior negative).

An equivalent circuit model of the neuronal membrane (Figure 16.4) permits consideration of other conditions, such as the response of a cell to an applied

voltage or current. In these cases, the membrane potential departs from the resting potential and the equivalent circuit can be used to analyze the resulting time-dependent and steady-state current changes.

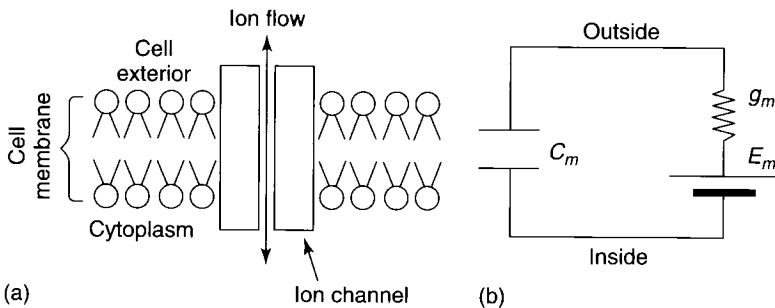

Fig. 16.4 A cell membrane and its equivalent circuit. (a) Each ion-conducting pathway in the membrane contributes to the membrane potential. (b) Lumped presentation of the permeability pathways. C_m , g_m , membrane capacitance and conductance, respectively. E_m , membrane potential.

16.3.2

Chemical-to-Electrical Transduction

Synapses are structures that facilitate transmission of signals between neurons. Two general types of synapses are recognized, depending on the source of the ions that enter the postsynaptic cell (Figure 16.1). In a chemical synapse (the characteristic linkage between neurons in the mammalian nervous system), there is a 20–30 nm gap between membranes of two cells; the diameter of the gap is 1–2 μm . A neurotransmitter (Table 16.1) synthesized and secreted by the presynaptic cell diffuses across the gap and reversibly binds to *receptors* on the postsynaptic cell. As a result, membrane channels in the postsynaptic cell open or close, thereby altering ion flow between the interstitial fluid and the neuron interior. Typical binding constants are in the range of 10^5 – 10^7 M^{-1} . In some cases, the neurotransmitter receptor and the pore through which the ions pass are part of a unitary transmembrane protein complex; in other cases they are distinct proteins and the events at each site are coupled by intracellular second-messengers (Figure 16.1).

Direct gating of ion channels involves a change in the conformation of only a single macromolecule, and can therefore occur on the order of milliseconds. Channels activated by second messengers are slower because they involve a series of reactions. In both cases, the ion flow produces a change in the membrane potential of the postsynaptic cell in the vicinity of the entry point of the ions into the cell. If Cl^- enters, the resting membrane potential (typically about -65 mV) becomes more negative, resulting in a hyperpolarization; entry of cations produces a

depolarization. Hyperpolarization of the neuronal membrane inhibits neuronal activity (Eqs (1) and (3)), and depolarization produces the opposite effect. The neurotransmitter is removed from the synaptic gap by a pump in the presynaptic membrane or by means of enzymatic degradation.

In a gap junction synapse (Figure 16.1), the presynaptic and postsynaptic cells are linked by conducting channels that permit ionic flow between them. Gap junctions (also called *electrical synapses*) are relatively rare in mammalian nervous systems compared with those of lower vertebrates and invertebrates.

Postsynaptic membranes provide chemical-to-electrical transduction. The nACr in the postsynaptic membrane of a neuromuscular synapse is a representative transducing element (neurotransmitter-gated ion channel). The receptor shows little selectivity among cations, and consequently the relative contributions to the channel current are determined by the cationic driving forces. For a typical neuron, the Na^+ concentration is far from Nernst equilibrium (unlike K^+ concentration). Consequently both the Na^+ gradient and the membrane voltage act to drive Na^+ into the cell, rendering it the principal nACr current. The net result of the acetylcholine-induced cationic conductance is the production of an electrical depolarization in the vicinity of the membrane containing the nACr (positive shift from the resting value). The total transmembrane current at the synapse is the sum of the ion flow through several hundred thousand such transmitter-gated channels, each of which has an identical conductance but an open-time governed by stochastic processes.

The biophysical principles governing synapses at the neuromuscular junction also apply to synapses in the central nervous system (CNS). However, signal transduction in the CNS is complicated by several factors.

1. A typical CNS neuron receives many simultaneous excitatory and inhibitory inputs (synapses involving vertebrate skeletal muscle are always excitatory).
2. Many different neurotransmitters may be involved in signal transduction by one neuron, and a given neurotransmitter may have more than one kind of receptor at the cell membrane.
3. The actual role of the neuron in the signaling pathway is determined by the sum of its excitatory and inhibitory inputs, and not merely by the occurrence of the inputs (at the

neuromuscular junction each synaptic potential tends to produce an action potential).

4. The indirect mechanism (Figure 16.1) for the effect of neurotransmitters on membrane potential can result in (i) channels that open or close at the resting potential; (ii) transient changes in membrane voltage that last much longer than those caused by directly gated channels; and (iii) second messengers that cause effects in addition to those on channel conductance (alterations in receptors for other neurotransmitters and in gene expression, for example).

16.3.3

Signal Summation

A transient neurotransmitter-induced voltage change at a synapse has no

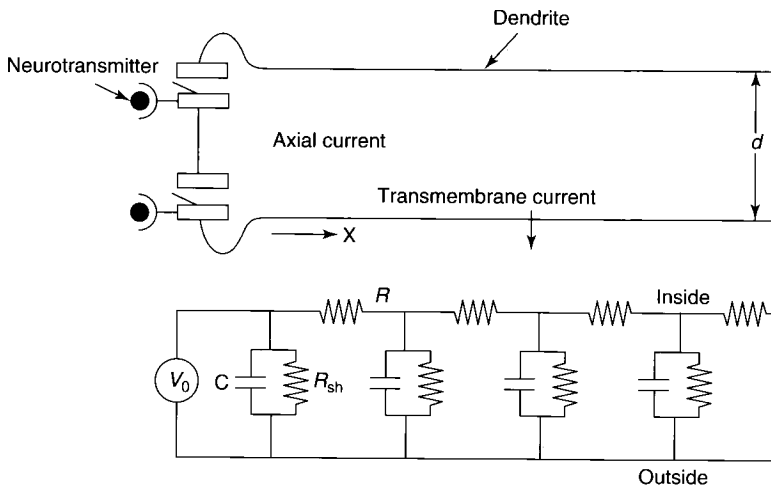

Fig. 16.5 Electrotonic spread of voltage in a dendrite and the corresponding equivalent circuit. (a) Binding of neurotransmitter molecules initiates a change in the membrane potential (V_0) induced by ion flow through neurotransmitter-gated channels in the dendrite. (b) V_0 propagates through the dendrite, which is represented as a series of segments with capacitance C and resistance R_{sh} , connected by resistance R .

individual significance with regard to the information transmitted by the postsynaptic neuron; physiological significance resides in the sum of the transients that propagate to the axon hillock. Signal propagation can be modeled in terms of the response of a lossy insulated wire embedded in a conducting medium (Figure 16.5) (Deutsch and Micheli-Tzanakou, 1987). The dendrite is conceptually divided into a series of isopotential segments of length ∂x and diameter d represented by a membrane capacitance C in parallel with a transmembrane resistance R_{sh} ; each adjacent pair of segments is connected by the axonal resistance R , where $R = 4\rho\partial x/\pi d^2$ and ρ is the resistivity of the cytoplasm. A voltage transient occurs at a synapse on the distal portion of the dendrite as a result of an ion flux, and a portion of the resulting current charges the local membrane capacitance thereby increasing or decreasing the membrane potential (depending on the charge of the permeant ion). The remaining current splits and either charges the capacitance of the second segment, passes through the membrane and completes the circuit back to its source, or continues on to the next segment. This process continues until all the current has leaked out and returned to its source via the extracellular fluid, which is assumed to have negligible resistance. From Ohm's and Kirchoff's laws, the equation governing the spread of the potential $V(x, t)$, measured from the resting potential, is

$$\lambda^2 \frac{\partial^2 V}{\partial x^2} = \tau_m \frac{\partial V}{\partial t} + V \quad (2)$$

where $\lambda = \sqrt{R_{sh}/R}$ is the length constant and $\tau_m = R_{sh}C$ is the time constant. In terms of C_m and R_m , which are the capacitance and resistance per unit area,

respectively, we have $\lambda = \sqrt{R_m d/4\rho}$ and $\tau_m = R_m C_m$; typically, C_m is assumed to be about $1 \mu\text{F cm}^{-2}$. Both τ_m and λ depend on the type of neuron; values for the hippocampal pyramidal cell are $\tau_m = 15\text{--}70 \text{ ms}$ and $\lambda = (0.5\text{--}1.5)l_0$, where l_0 is the length from the tip of the dendrite to the cell body.

The general solution for $V(x, t)$ is known (Rall, 1960), but the behavior of the potential can be inferred from a consideration of the simplest special cases. The steady-state solution for an infinitely long dendrite (applicable to slow synaptic potentials and to background depolarizations, as in cells in the retina) is $V = V_0 e^{-x/\lambda}$. Since $\rho \approx 1 \Omega\text{m}$ in all neurons, the spatial characteristics of the potential are determined by the membrane resistance and the dendrite diameter. The spread of the potential in finite dendritic systems depends on the nature and extent of the branching that occurs. If the diameters of the dendrites at a branching point are such that $d_0^{3/2} = \sum_i d_i^{3/2}$, where d_0 is the diameter of the parent dendrite and d_i are the diameters of each of the daughter branches, then the branches are electrically equivalent to the stem, and the potential spreads through the entire system as it would in an infinite dendrite (Rall, 1960). This model is useful for calculating the passive spread of potential in dendritic systems (*electrotonus*), and can be used to estimate λ for the dendritic tree.

The membrane time constant is an important determinant of the time course of the postsynaptic potential, but a precise description depends upon many factors including the model chosen. The essential feature of all realistic models is the prediction of an amplitude diminution

and pulse-width increase as the postsynaptic potential propagates from its origin. Thus synapses near the cell body facilitate relatively large and rapid responses, whereas distant inputs lead to weaker and slower changes in the membrane potential at the cell hillock (site of generation of the action potential).

Neurons have evolved mechanisms by which they can receive synapses at their distal dendrites and still transmit large, rapid postsynaptic potentials to the axon hillock. These mechanisms include

1. the presence of a high specific membrane resistance;
2. production of a particularly large postsynaptic potential; and
3. the occurrence of active membrane processes in dendrites, for example voltage-gated ion channels responsible for the action potential (see below).

The net effect of simultaneously activated synapses depends on their location in the dendritic tree. When neighboring synapses are activated simultaneously, the conductance changes interact nonlinearly, thereby precluding a general analysis of the responses. At widely separated synapses, the overall response may be described in terms of a superposition of the individual postsynaptic potentials.

Dendritic spines (Figure 16.6) are narrow projections from the dendrites; they are found on many types of neurons and can be the locus of synaptic inputs. The structural and electrophysiological characteristics of spines are not well understood; they may exhibit properties and functions not occurring elsewhere in the dendritic system. For example, the dendritic spine might provide a high-resistance path for a postsynaptic potential into the dendritic tree;

this would have the effect of electrically isolating its postsynaptic potential from those induced at synapses on the dendrite itself. Consequently, the dendrite–synapse postsynaptic potential and the spine–synapse postsynaptic potential would add in a more nearly linear fashion than if both potentials occurred side by side directly on the dendrite.

Although the basic response of each portion of the dendritic membrane to a voltage change is a propagating, diminishing voltage transient, the overall response of the neuron is difficult to characterize because of its highly complex morphology. A neuron (Figure 16.6) may contain 30 000 synapses, any combination of which may simultaneously transmit either inhibitory or excitatory postsynaptic potentials, all of which are processed in parallel. Specialized computer programs have been developed to accommodate many degrees of freedom needed to apply the cable equation to realistic models of actual neurons (McKenna, Davis and Zornetzer, 1992).

The role of dendrites was traditionally thought to be limited to that of supporting the passive unidirectional propagation of current, but new evidence suggests that dendrites can also integrate and process bidirectional information. Back-propagation of axon-derived action potentials (*antidromic action potentials*) has been demonstrated in the hippocampus (Magee and Johnston, 1997) and neocortex (Markram *et al.*, 1997), and shown to be necessary for long-term potentiation. Subthreshold synaptic inputs that were followed rapidly by the arrival of back-propagating action potentials facilitated amplification of subsequent subthreshold synaptic inputs. Variations in

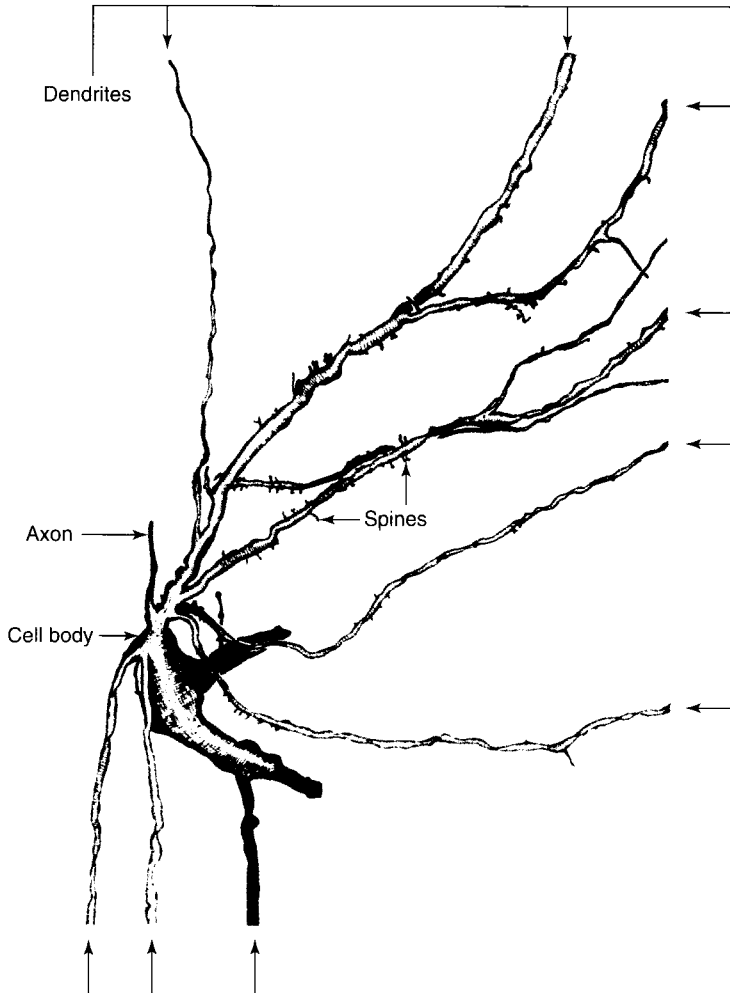

Fig. 16.6 Drawing of a sensory neuron from the dorsal horn of the spinal cord of a Macaque monkey. Only a portion of the dendritic tree and axon is shown. A typical sensory neuron receives about 20 000 synapses. The shading indicates relative depth. Courtesy of John A. Beal.

the timing of the signals altered the *plasticity* of the synapses (Sejnowski, 1997), which has implications for the process of memory formation (see below). Thus, it appears that dendrites may have an important and previously unrecognized role in synaptic plasticity.

If the voltage sum from all synaptic inputs exceeds a threshold (typically

≈ 30 mV) at the axon hillock, then an action potential is generated and propagates along the axon.

16.3.4

Action Potential

An action potential is a local, transient change in membrane potential that

propagates at 0.5–110 m s⁻¹ (depending on the type of neuron). The biophysical process underlying development of the action potential was elucidated by Hodgkin and Huxley in a classic series of studies that employed the *voltage-clamp* technique (Figure 16.7) (Hodgkin and Huxley, 1952). The voltage-clamp (applied voltage, V_m) was particularly useful because it permitted direct control over the fundamental variable (voltage dependence of membrane conductance).

The current across the membrane was described in terms of a capacitive and

three ionic components (Figure 16.8):

$$I_m = C \frac{dV_m}{dt} + g_{Na}(V_m - E_{Na}) + g_K \times (V_m - E_K) + g_L(V_m - E_L) \quad (3)$$

where C is membrane capacitance and E_{Na} , E_K , and E_L are the reversal potentials for the Na⁺, K⁺, and leak ions, respectively. The electrical excitability of the membrane is contained in the voltage- and time-dependent conductances, g_K and g_{Na} ; g_L is a leakage conductance (undetermined ionic composition). By varying V_m and the concentrations of the ions and by using radioactive K⁺,

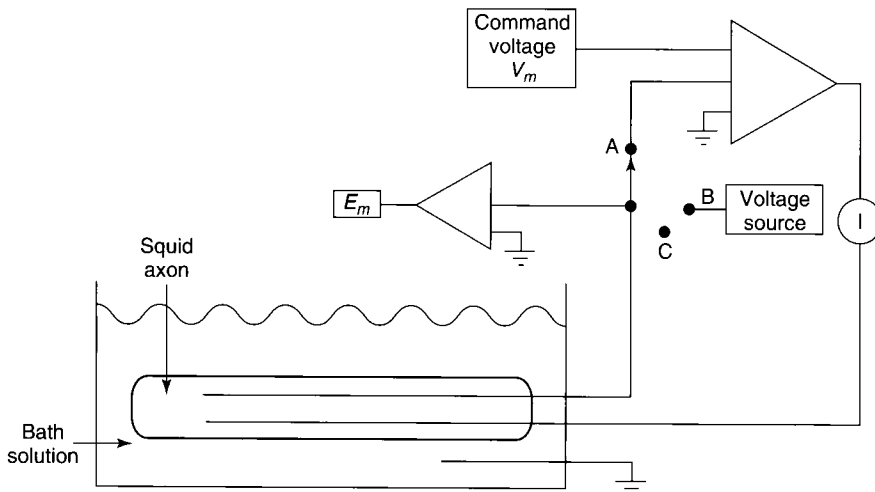

Fig. 16.7 The voltage-clamp technique and measurement of the action potential in the squid axon. For voltage-clamp measurements (switch position A), a voltage-recording electrode and a current-delivering electrode are placed intracellularly. The output of the feedback amplifier is determined by the difference between the command voltage (V_m) and the membrane potential (E_m). For nonzero differences, the amplifier drives a current through the membrane in such a direction as to reduce the difference to zero. When a voltage step is applied, the membrane capacitance becomes charged in a time in the order of microseconds; thereafter, the capacitive current does not contribute to the membrane current. The circuit permits an abrupt displacement of the membrane potential that can be maintained indefinitely at the new value as the membrane current is measured. The design of the electrodes prevents the flow of longitudinal currents. In switch position B, the voltage-clamp is removed, and a brief (100 μ s) voltage pulse is applied between the voltage measuring and bath-solution electrodes; if the switch is then moved to the open-circuit position C, the axon develops an action potential or returns to baseline, depending on whether the depolarizing pulse reached the threshold level.

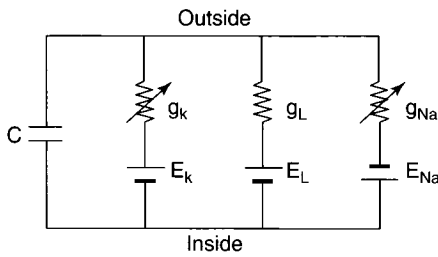

Fig. 16.8 Pathways for current flow in the Hodgkin–Huxley model of the axon. In voltage-clamp studies, capacitive current flows only during the time the potential is changing; thereafter, the membrane current consists solely of an ion flow through the three ion-conductive branches represented by Na^+ , K^+ , and leak conductances. The batteries depict the Nernst equilibrium potentials; time- and voltage-dependent conductances are employed to explain the response of the membrane to changes in voltage.

Hodgkin and Huxley showed that the early inward current in the voltage-clamped squid axon was due to Na^+ entering the axon, and that the later-appearing outward current was due to K^+ leaving the axon (Figure 16.9). To provide a basis for reconstructing the action potential, they measured the time variations of g_{Na} and g_{K} for various values of the membrane potential using an ion-substitution method (pharmacological methods are now used for dissecting the Na^+ and K^+ currents). The mathematical description that they formulated to explain the transmembrane current responsible for the action potential consisted of three empirical equations

$$\begin{aligned} g_n(V_m, t) &= \bar{g}_n \Phi^{\alpha} X^{\beta} \\ \dot{\Phi}(V_m, t) &= \frac{1}{\tau_{\Phi}} (\Phi_{\infty} - \Phi) \\ \dot{X}(V_m, t) &= \frac{1}{\tau_X} (X_{\infty} - X) \end{aligned} \quad (4)$$

where n is Na^+ or K^+ ; Φ and X are gating variables for activation and inactivation, respectively, representing the fraction of the maximum conductance at any given time and voltage; \bar{g}_n is the maximal value of the conductance, and α and β are constants. The time constants (τ_{Φ} , τ_X) and the steady-state values for

activation and inactivation (Φ_{∞} , X_{∞}) are functions of ion type (Na^+ , K^+) and V_m , and are adjusted empirically. For Na^+ channels $\alpha = 3$, $\beta = 1$, for K^+ channels $\alpha = 4$, $\beta = 0$.

The Hodgkin–Huxley equations (Eq. (4)) and the cable equation (Eq. (2)) are sufficient to explain propagation of the action potential, the existence of the voltage threshold, and the velocity of propagation. Despite some limitations, the model is the generally accepted explanation of the origin and characteristics of the action potential in the peripheral and central neurons of invertebrates and vertebrates. The complex pattern of electrical activity found in the nervous system arises from the interplay of the Hodgkin–Huxley mechanism, neuronal structural complexity, and ion-channel diversity.

When the action potential arrives at the axonal terminal, it is transduced into a chemical signal.

16.3.5

Electrical-to-Chemical Transduction

Neurotransmitter molecules are stored in the axon terminal in specialized organelles called synaptic vesicles. When the action potential arrives at the

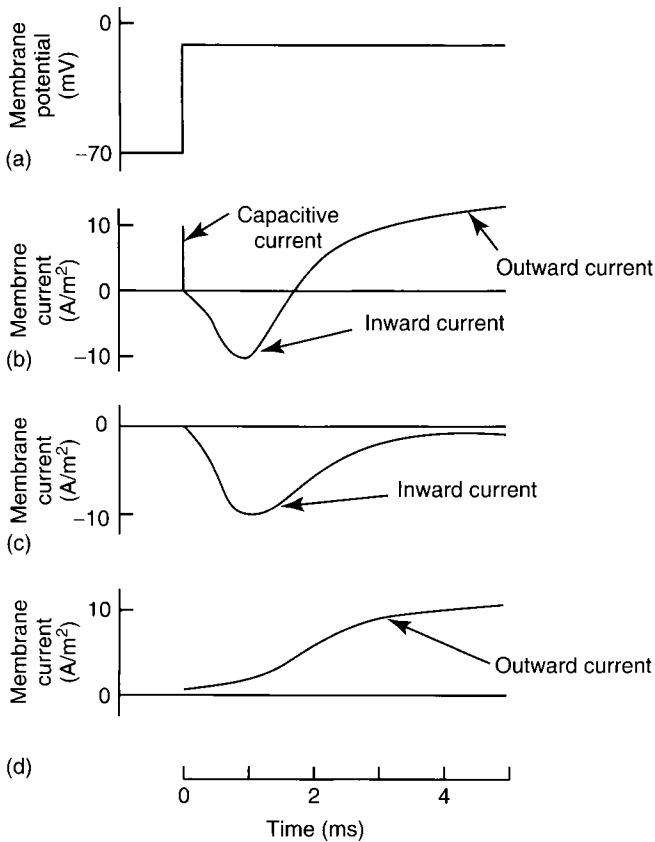

Fig. 16.9 Current flows across the squid axon under voltage-clamp conditions. During a depolarization of the membrane potential (a), an early inward and later outward current is observed following the capacitive transient. The ionic current flow (b) can be resolved into the sum of an inward Na^+ current (c) and an outward K^+ current (d).

terminal, the depolarization opens voltage-gated Ca^{2+} channels that are concentrated there, and the resulting Ca^{2+} influx triggers a series of protein interactions that cause the vesicle membranes to fuse with the presynaptic membrane resulting in neurotransmitter release into the synaptic cleft (Kandel, Schwartz and Jessell, 2000). In some cases, the vesicles fuse only slightly with the membrane rather than integrating fully into it, thereby resulting in faster recycling of the vesicle membrane.

Thus, presynaptic membranes provide electrical-to-chemical transduction.

A small baseline level of neurotransmitter release into the synaptic cleft occurs spontaneously under resting conditions. The effect of the arrival of each action potential at the axon terminal can be viewed as a Bernoulli trial with regard to the fate of individual vesicles. A higher frequency of action potentials results in a longer time during which the membrane is depolarized, thereby permitting a greater Ca^{2+} influx and a

greater number of fused vesicles; thus, neurotransmitter release is a graded response.

16.4 Neuronal Systems

16.4.1 Overview

Specialized neurons or neuroepithelial cells called *sensory receptors* detect external stimuli and transduce them into electrical signals, the language of the nervous system. The signals are processed by groups of neurons in local neuronal networks whose activity may be synchronized with that in other regions of the nervous system. Synchronization is accomplished by neurons that are hard-wired between local networks and by *volume transmission* mediated by electrical and chemical messengers. The ultimate result of the sensory inputs and subsequent regional interactions is the behavior manifested by the organism. Not surprisingly, mechanistic knowledge of neuronal systems is inversely related to the complexity of the level of the activity under consideration. There is convincing evidence that sensory receptor function is mediated by changes in conductance of ion channels, but the mechanisms for higher brain functions, such as behavior, *memory*, and consciousness, are poorly understood.

16.4.2 Sensory Systems

Mechanical, energetic, and chemical stimuli are transduced by receptor cells (Table 16.2), resulting in electrical activity that serves as the basis of

conscious or unconscious perception of the internal and external environment, and that controls the autonomic regulatory systems in the body. Some life forms possess sensory capabilities not presently known to occur in human beings. In the case of electroreception, for example, the catfish *Kryptopterus bicirrhis* can detect the presence of $2 \mu\text{V m}^{-1}$ at 10 Hz (Kolomytkin *et al.*, 2007). Magnetoreception, which was known to occur in bacteria and birds, was recently discovered in human beings (Carrubba *et al.*, 2007).

In all known sensory systems, stimulus transduction is mediated by a change in conductance of ion channels. The stimulus may interact with a membrane receptor protein coupled to a channel protein via a second-messenger system, as in the cases of chemical and light stimuli. Alternatively, the stimulus may act directly on the channel to produce a deformation that alters conductance, as in the sense of touch. In all cases, transduction ultimately produces a change in channel conductance that gives rise to a change in membrane potential called the *receptor potential*. The receptor potential is smoothly graded in proportion to the strength of the stimulus, and propagates electrotonically to the presynaptic membrane (neuroepithelial cell) or to the site of generation of an action potential (neuron).

Signal transduction can be illustrated by considering the retinal photoreceptor cells (Figure 16.10). The cells have a membrane potential of about -40 mV in the absence of light, and become hyperpolarized in proportion to the intensity of the absorbed light (Figure 16.10a), thereby reducing the amount of neurotransmitter (glutamate) normally released onto neurons synapsed with

Tab. 16.2 Main types of sensory modalities.

Sense	Stimulus	Receptor Cell	Receptor Location
<i>Mechanical</i>			
Balance	Mechanical	Hair cells	Vestibular organ
Hearing	Mechanical	Hair cells	Cochlea
Pressure	Mechanical	Neurons	Tissue
Vascular pressure	Mechanical	Neurons	Blood vessels
Muscle stretch	Mechanical	Neurons	Muscle spindle
Muscle tension	Mechanical	Neurons	Tendons
Joint position	Mechanical	Neurons	Ligaments
Osmotic pressure	Osmotic pressure	Osmoreceptors	Hypothalamus
Pain	Various	Neurons	Many organs
<i>Energetic</i>			
Vision	Photons	Photoreceptors	Retina
Temperature	Temperature	Neurons	Tissue
Electroreception	Electric fields	Electroreceptors	Skin (brain?)
Magnetoreception	Magnetic fields	Magnetoreceptors	Unknown
<i>Chemical</i>			
Arterial oxygen	O ₂ tension	Neurons	Carotid body
Glucose	Glucose	Glucoreceptors	Hypothalamus
pH (cerebrospinal fluid)	Ions	Ventricle cells	Medulla
Taste	Chemicals	Taste-bud cells	Tongue
Smell	Molecules	Olfactory receptors	Nose
Pain	Various	Neurons	Many organs

the photoreceptor cell. The molecular details (Figure 16.10b) involve opsin, a G-protein-coupled receptor, and 11-*cis*-retinal, a light-absorbing chromophore bound to the opsin. In the absence of light, high levels of cyclic guanosine 3'-5' monophosphate (cGMP) keep cGMP-gated Na⁺ channels open, thereby allowing an inward Na⁺ current. Photon absorption by the chromophore activates transducin (the G protein) that induces phosphodiesterase to hydrolyze cGMP into GMP; this leads to the closure of Na⁺ channels, which causes the cell to become hyperpolarized (Fesenko, Kolesnikov and Lyubarsky, 1985).

Evolution employed the basic physical principles governing the interaction of force and matter to produce

many different mechanisms for transmembrane ion flow. Receptors that transduce mechanical force or pressure (mechanoreceptors) are examples. When the stimulus is applied to the gate of the ion channels, changes occur in transmembrane ion flow that result in the generation of receptor potentials according to the GHK equation. Some mechanoreceptors operate by means of cytoskeletal proteins that transmit force to the channel gate; in other cases force is applied by means of lateral tension in the cell membrane. Some mechanoreceptors trigger an action potential only when they produce a threshold receptor potential, while others continuously trigger action potentials with a certain frequency. In the latter cases, the force changes the probability of the channels

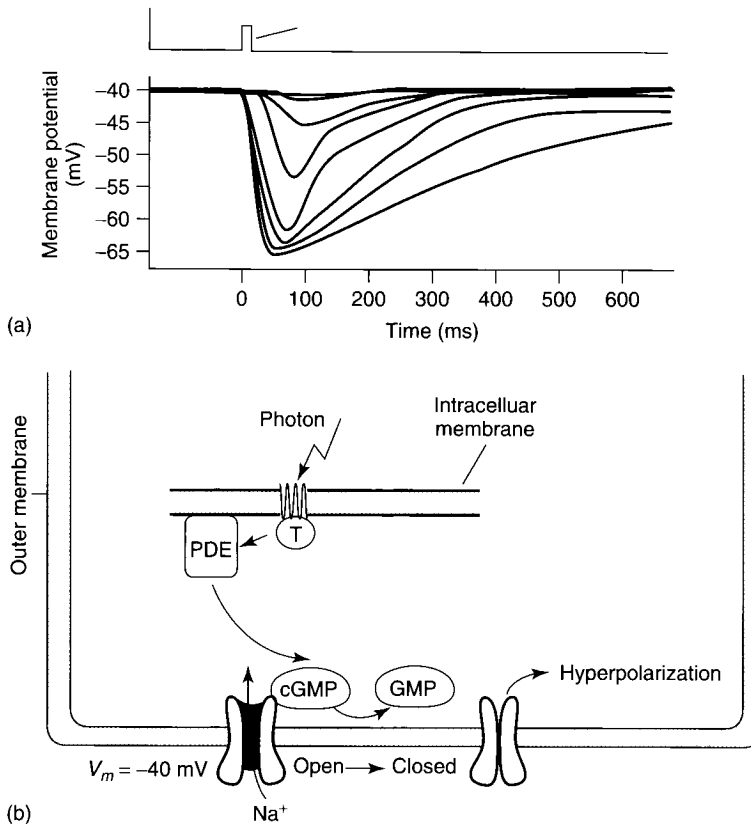

Fig. 16.10 Phototransduction in the retina. (a) Photoreceptor cell stimulated with progressively more intense light flashes becomes correspondingly more hyperpolarized. (b) One photon is sufficient to cause a change in the membrane conductance because of the amplification that occurs in the transduction cascade (a single activated chromophore can cause the hydrolysis of $> 10^5$ cGMP molecules). T, transducin; PDE, phosphodiesterase; and cGMP, cyclic guanosine 3'-5' monophosphate.

to be in the open state, thereby allowing continuous modulation of the frequency of the action potentials.

The hair cells in the inner ear have a well-understood force-transduction mechanism (Figure 16.11). Projections from the cells (stereocilia) contain ion channels whose gates are linked by specialized proteins. Deflection of the stereocilia by sound pressure results in a bending moment that changes the tension in the links, thereby changing the

probability of the channel to be in the open state (Kachar *et al.*, 2000). The stiffness of the stereocilia in hair cells of the bullfrog is about 1 mN m^{-1} , so that a force of 100 pN is sufficient to produce a deflection of $\approx 100 \text{ nm}$, which stretches the tip links by about 12 nm. The tip link works as a spring, shifting the channel gate by $\sim 2 \text{ nm}$, which is sufficient to open most channels. Myosin I molecules maintain resting tension on the channels to bias them to the most sensitive part

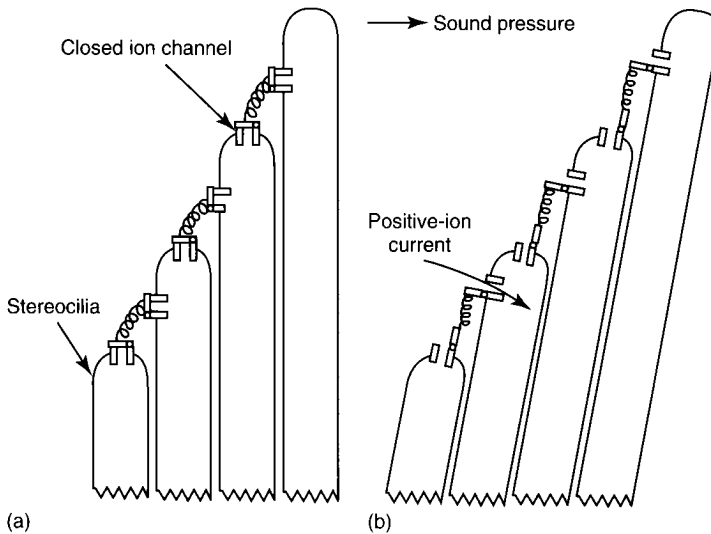

Fig. 16.11 Sound transduction by hair cells. (a) Stereocilia on hair cells contains ion channels whose gates are mechanically connected. (b) Sound pressure results in bending moments that open the channel gates.

of their activation curve (Sukharev and Corey, 2004).

The mechanisms responsible for the operation of exotic sensory systems such as electroreceptors are far less understood. It was suggested that Ca^{2+} channels in the apical and basal membrane provided the sensitive element (Bullock *et al.*, 2005). However, the electric-field sensitivity of all known Ca^{2+} channels is too low to account for the observed behavior of electroreceptors. One possibility is that the sensitive element is a gel particle connected to an ion-channel gate in the cell's apical membrane. In theory, mechanical displacement of the gel in small electric fields could open an ion-channel gate (Kolomytkin *et al.*, 2007).

16.4.3

Neural Networks

Receptor cells have no functional significance within the nervous system unless

they are part of a network. Network complexity varies across the phylogenetic scale from a simple two-cell reflex response to the highly complex neural networks that mediate human consciousness and behavior.

Mathematical neural networks have been developed (Section 16.4.3) in the hope that they could model biological learning. In such a network a neuron is modeled as a summing node that weights each input and transforms the sum in a predetermined manner to yield an output (Figure 16.12). Usually three or more layers of model neurons interconnected in such a way that the outputs of the model neurons in one layer are the inputs to the next layer. The output, f , of each neuron depends on other functions $f = f(g_1, g_2, \dots, g_n)$, where g_i are functions of other functions $g_i = g_i(h_1, h_2, \dots, h_m)$, and so on up to the first layer where the arguments are the input signals. The *back-propagation*

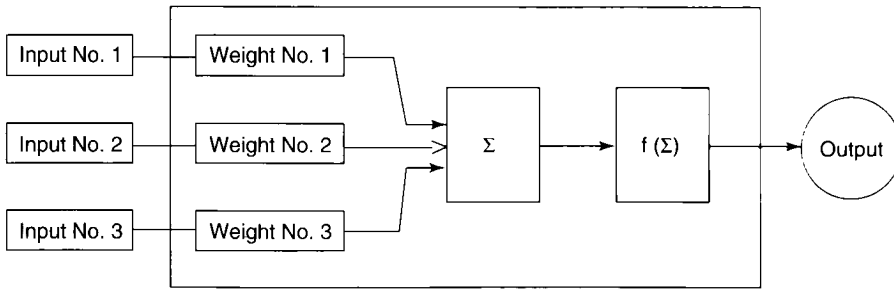

Fig. 16.12 Typical model neuron in an artificial neural network. The output is the transformed sum of the weighted inputs. A threshold is a common transfer function; in such a case, the weighted sum becomes the output only if it exceeds a specified level.

algorithm is an example. By following a systematic iterative procedure, the weights and transfer function of each model neuron can be adjusted so that the network produces correct outputs. In a sense, the artificial networks mimic the learning behavior of biological neurons, although they do not simulate the actual learning procedures used by the brain. The time required for an artificial network to learn increases rapidly as the size of the network increases, which is not true for brain networks. It is now clear that processing of information within the CNS is more complicated than that embodied in mathematical neural networks.

Biological neural networks are spatially localized functional units containing input and output neurons and local neurons that facilitate information-processing within the network. Operations within local networks are mediated by a combination of synaptic patterns (Figure 16.13). Synaptic divergence is a morphological pattern that amplifies neuronal activity by distributing it to many cells. Neurotransmitter release does not necessarily occur at each synapse within a particular morphological unit; in the neuromuscular junction, for example, only about 10%

of the synapses are activated by entry of the action potential into the presynaptic axon terminal (Shepherd, 1990). Synaptic convergence facilitates the spatial and temporal integrative function of the dendritic tree (Figure 16.13b and c). Presynaptic inhibition is a neuronal connectivity pattern in which a specific cell may be simultaneously presynaptic to one cell and postsynaptic to a second cell (Figure 16.13d); this arrangement permits a neuron to modify the activity of the cell without actually synapsing with it. The dendritic architecture together with the variety of possible synapses provide a wide range of computational possibilities, even in highly simplified networks (Figure 16.14). In general, the performance of biological neuronal networks is degraded if some of the component neurons fail, but catastrophic failure of the network does not occur.

16.4.4

Volume Transmission

In the hardwired model of the CNS, information transfer is mediated by synapses between adjacent cells (Figure 16.1), however, it can also occur via a nonsynaptic mechanism known

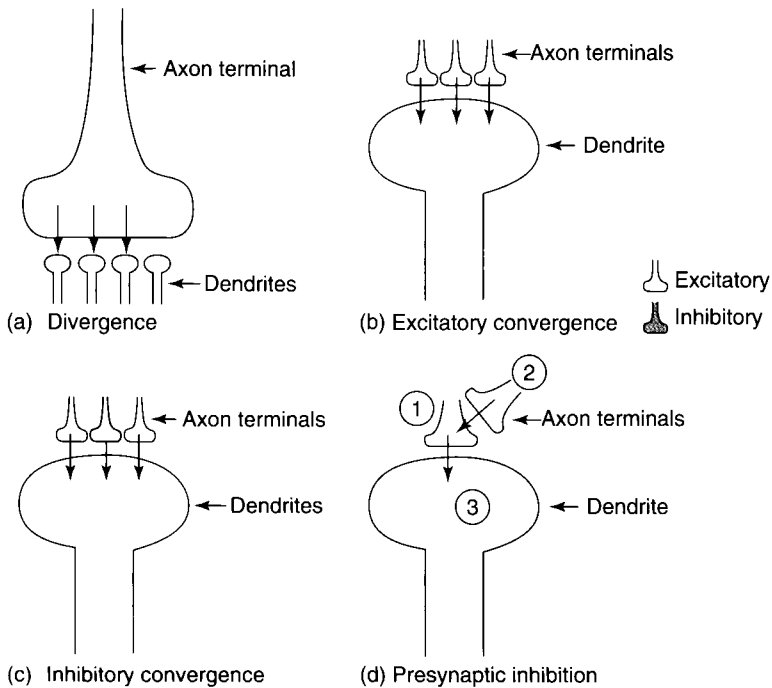

Fig. 16.13 Basic form of neuronal connectivity. (a) A divergent pattern produces a gain in activity (unless all but one of the synapses are silent). (b) and (c) Convergent patterns, which mediate neuronal integration. (d) Presynaptic inhibition. The effect of cell 1 on cell 3 is modified by cell 2, which does not directly affect cell 3 (adapted from Shepherd, 1990).

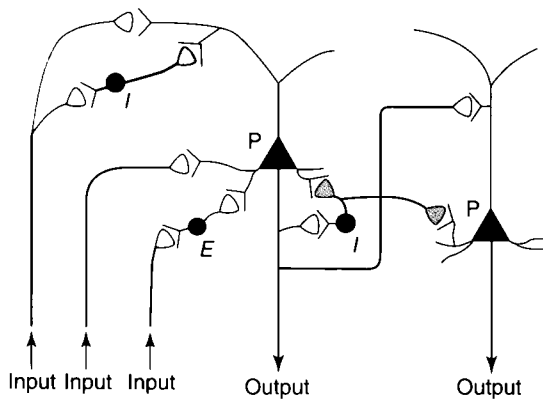

Fig. 16.14 Basic circuit organization of the cerebral cortex. Pyramidal neurons P receive inputs, generate outputs, and interact with one another. Local neurons may be inhibitory (I) or excitatory (E). Because of the cell density, dendritic architecture, and synaptic organization, there exist a vast number of computational possibilities (adapted from Shepherd, 1990).

as *volume transmission*. For example, potentials produced by groups of cells propagate in the electrically conductive extracellular fluid and induce effects in

distant cells such as synchronizing or altering their firing probability (Bullock, 1997). For the special case of n point current sources in a homogeneous

conductor, the potential is

$$V(\mathbf{r}, t) = \frac{1}{4\pi\sigma} \sum_{i=1}^n \frac{I_i(t)}{R_i} \quad (5)$$

where $I_i(t)$ is the total current flowing from the i th point source into a medium of conductivity σ and R_i is the distance of the i th source from the field point \mathbf{r} . Thus, in principle, ionic flow in each neuron makes a contribution to the electrical environment of all other neurons in the CNS.

Diffusion of neuroactive substances through the brain (*volume diffusion*) is another important form of volume transmission. Neurotransmitters or other molecules may be released in a region not containing synapses (or may escape from the region of a synapse) and diffuse to other parts of the CNS through the cerebrospinal fluid in the extracellular space of the brain, which occupies about 20% of the brain's volume, thereby reaching distant targets.

Neuropeptides (a subset of neurotransmitters) are good candidates for volume transmitters because they are present in the extracellular fluid for relatively long periods and have relatively high affinity for their receptors. Neuropeptide Y, which is released in certain regions of the thalamus and hypothalamus, is an example. The receptors for neuropeptide Y are located several millimeters from the points of release; since it diffuses through the brain at about 1 mm h^{-1} , the spatial separation of secretion and binding of neuropeptide Y suggests that it may mediate slow information transfer within the brain.

Nitric oxide and carbon monoxide are also possible volume signaling agents. Nitric oxide is produced in both neurons

and glia, and can quickly diffuse through the tissue.

In addition to isotropic diffusion, preferential diffusion along extracellular fiber bundles within the brain may occur (Bjelke *et al.*, 1995).

The traditional view was that neurotransmitter release always involved calcium-dependent fusion of neurotransmitter-laden vesicles at neuronal presynaptic membranes. However, *uptake carriers* can also secrete neurotransmitter (Atwell, Barbour and Szatkowski, 1993) via a nonvesicular process that does not require Ca^{2+} and that usually occurs away from the synaptic cleft. Thus, uptake carriers provide a possible source of diffusible neuroactive agents.

16.4.5

Brain Electrical Activity

Postsynaptic potentials and action potentials propagate electronically by volume conduction, yielding the *electroencephalogram* (EEG), a nonstationary, time-dependent voltage measured on the scalp. Spontaneous changes in the EEG are pathognomonic for some diseases, including brain tumors, epilepsy, and infection. Changes in the EEG induced by sensory or cognitive stimuli are called *evoked potentials*; they are used to study brain function and to detect abnormalities in the nervous system.

Even though it is universally agreed that brain electrical activity is nonlinear, the mathematical methods normally used to extract information from the EEG have been linear; chief among them are Fourier analysis and time averaging. Phase-space-based methods and other nonlinear techniques hold great promise for revealing previously unsuspected aspects of organized neuronal activity.

For example, consider the problem of determining whether environmentally strong electromagnetic fields (EMFs) are transduced by the mammalian nervous system. In principle, a solution could be found by comparing the EEG in the presence and absence of an EMF; a statistically reliable difference would indicate that transduction had occurred. This problem defied solution by traditional linear methods of analysis but was solved (Carrubba *et al.*, 2007) using a nonlinear method known as *recurrence analysis* (Webber and Zbilut, 1994), which is capable of detecting

deterministic dynamical activity in a nonstationary signal such as the EEG (Figure 16.15).

16.4.6 Learning and Memory

Memory, the accessible storage of information, is encoded in multiple regions in the brain by different neuronal circuits depending on whether the memories are explicit (facts) or implicit (skills, habits, and behaviors) (Kandel, Schwartz and Jessell, 2000). The encoding is believed to consist of changes in the patterns of

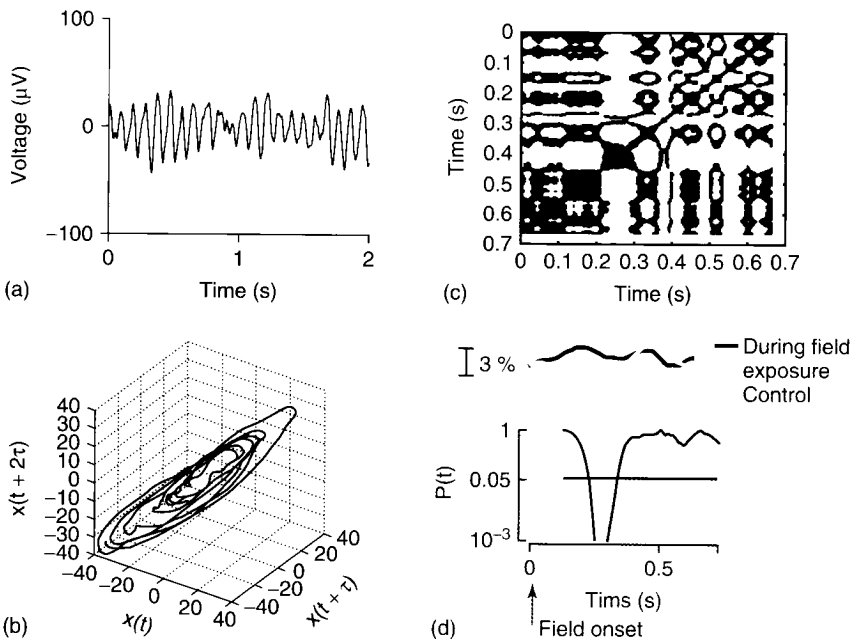

Fig. 16.15 Use of recurrence analysis to detect an onset evoked potential triggered by a 2-gauss, 60-Hz magnetic field. (a) Typical electroencephalogram recorded from the scalp of a 20-year-old male. (b) Appearance of the electroencephalogram in a three-dimensional phase-space ($\tau = 3.3$ ms). (c) Recurrence plot corresponding to the phase-space plot. (d) Upper curves, numerical characterization of a series of recurrence plots, using the recurrence analysis parameter percent recurrence (Webber and Zbilut, 1994). The gray curve is the average value of a series of control epochs. The solid curve is the average of the experimental epochs (field turned on at $t = 0$). The subject exhibited a nonlinear magnetosensory evoked potential about 300 ms after field onset. P, probability of a difference between exposed and control epochs (Carrubba *et al.*, 2007).

synaptic connections among neurons. If the pattern plasticity is labile, the result is *short-term memory*; if the change is permanent, the information is essentially imprinted on the organism resulting in *long-term memory*.

The NMDA glutamate postsynaptic receptor is believed to play a crucial role in formation of long-term memory (Kandel, Schwartz and Jessell, 2000). The receptor's ion channel opens when glutamate and glycine are bound to the receptor while the postsynaptic membrane is depolarized. The necessary conditions are provided by the occurrence of repeated nerve pulses and the presence of other glutamate receptors. The low-selective cation channel of the

NMDA receptor transfers Ca^{2+} from outside to inside the cell.

It is assumed that long-lasting improvements in synaptic transmission occur when the intracellular calcium concentration exceeds a critical threshold in the postsynaptic compartment. One possible explanation involves the irreversible activation of a calcium–calmodulin-dependent kinase (CaMK) by Ca^{2+} ions. After activation, CaMK can phosphorylate and regenerate itself independently of Ca^{2+} (Figure 16.16). Mathematical models have predicted that spontaneous reversion to the inactive state would be unlikely, and the active Ca^{2+} -independent state could potentially last a lifetime. The kinase

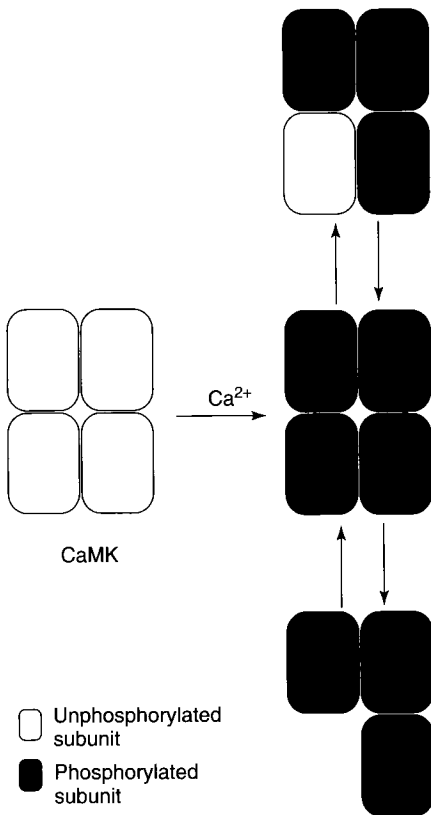

Fig. 16.16 Irreversible activation of calcium–calmodulin-dependent kinase (CaMK). In the inactivated state, CaMK's subunits are unphosphorylated. Stimuli that induce memory activate CaMK by Ca^{2+} -dependent phosphorylation of the subunits; thereafter, autophosphorylation occurs independently of Ca^{2+} . Thus, if a subunit becomes dephosphorylated (top), CaMK can return to full activity by means of a Ca^{2+} -independent process. If a subunit becomes unbound or degraded (bottom), the subunit is replaced independently of Ca^{2+} (Hanson and Schulman, 1992).

could, therefore, mediate long-term potentiation in synaptic function by phosphorylating another protein, for example AMPA receptor (Nayak, Moore and Browning, 1996).

Other mechanisms involved in the production of late long-term memory involve induction of specific changes in gene expression and protein synthesis by persistent activation of protein kinases (Pastalkova *et al.*, 2006; Serrano, Yao and Sacktor, 2005).

It has been argued that memory is distinct from events that occur at the cellular and molecular levels, and therefore there is no necessary conceptual link between behavior and the underlying physical processes (Skinner, 1966). If the issue of memory formation is approached from this perspective, the goal becomes one of understanding the principles that govern formation of the neural networks that mediate memory (as opposed to the goal of discovering molecular mechanisms). One of the most advanced efforts in this regard is that of Tsien and his colleagues. A broad outline of their work is given below; readers interested in the details should consult the original reports (Lin *et al.*, 2007; Lin *et al.*, 2005; Lin, Osan and Tsien, 2006).

When a memory-producing event (MPE) occurs, the baseline spiking activity of the neurons involved in encoding the memory exhibit four different kinds of changes (Figure 16.17a). Tsien and colleagues developed a device that allowed simultaneous monitoring of hundreds of randomly selected neurons in the hippocampus of an awake freely moving mouse, and then observed the responses to various MPEs (Figure 16.17b). When the results were analyzed using a pattern-recognition algorithm and then projected

to a three-dimensional space (D-space) whose axes were abstract concepts that bore no relation to ordinary physiological parameters, clustering of the patterns from a particular mouse subjected to different MPEs was observed (Figure 16.17c), indicating that different events were encoded by different changes in spike activity. Once the memories were generated and characterized by D-space analysis, they could be observed to occur spontaneously, suggesting that the mouse was remembering a particular event.

Further analysis of the structure of each of the D-space clusters led to the discovery of the existence of groups of neurons (cliques) that were activated by some MPEs but not others. For example, a particular clique might be activated by a fall or a shake but not a drop, whereas another clique might be activated by a fall or a drop, but not by a shake. Analysis of the differential response of the cliques in the context of different MPEs provided good evidence for the existence of a hierarchical basis for memory formation that consisted of a kind of binary code represented by the activation and nonactivation of particular neural cliques (Figure 16.17d).

In summary, neural cliques appear to serve as functional coding units that give rise to memories. Different cliques extract distinct features of an event; the activated cliques are linked in the brain to form an accessible, categorical, hierarchical representation of the event. This structure permits new memories to be formed by means of modifications or substitutions in the code for previous memories. For example, this time the man standing on the corner is wearing a white shirt. Thus the brain is not like a camera that records every detail, but

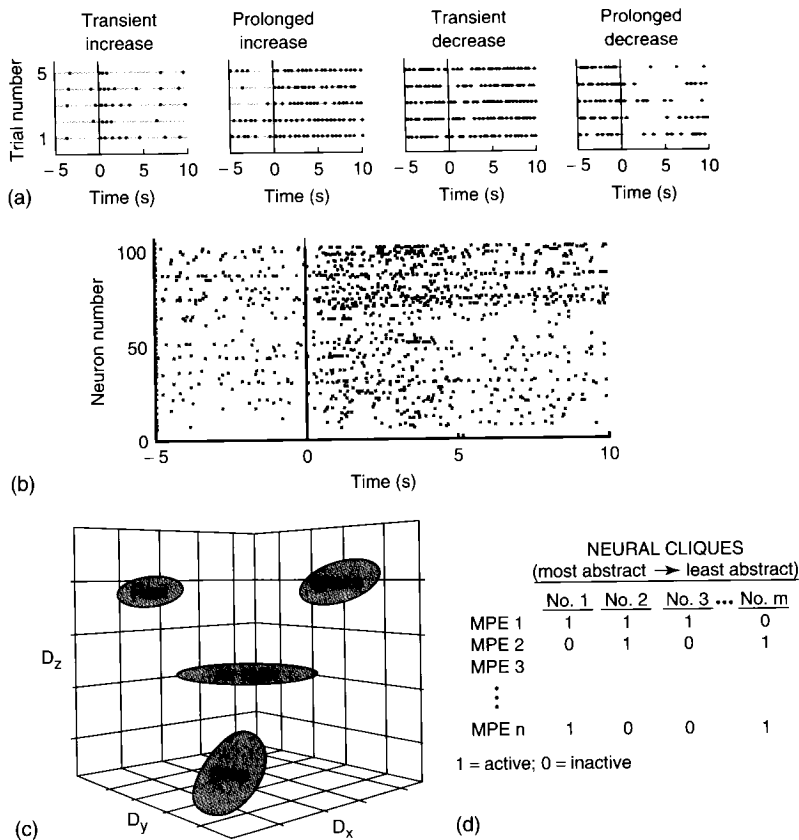

Fig. 16.17 Experimental detection of memory formation in a mouse. (a) Spike raster plots for five repetitions of an event, showing the four major types of changes that occur in the spike patterns (stimulus applied at 0 seconds). (b) Spike raster plots of 100 simultaneously recorded neurons in a mouse (stimulus applied at 0 seconds). (c) Locations in D-space associated with four different memory-producing events (MPEs). (d) Binary codes for specific MPEs.

rather functions by abstracting features that are common to quite different MPEs. A hierarchical organization of neural cliques also provides a general means for representing other types of information such as sensory perception.

16.4.7

A Nonlinear Future

As we said in the beginning, neurobiophysics is the study of the structure and

function of the nervous system as seen from the perspective of physics, which is the view that a proper description of nature's behavior should be formulated in mathematical terms involving abstract concepts. Neurobiophysics began with the development of the Hodgkin–Huxley (HH) equations. Although they are still regarded as the prototypical explanation for the development of the action potential, there is no reasonable hope of being able to explain

the behavior of neuronal networks based on the reductionistic approach embodied in the HH equations.

Virtually all the great advances in neuroscience have been based on a reductionistic approach to the nervous system, which is more or less equivalent to assuming that it is essentially linear and seeking the knowledge that could be gained under this assumption. Perhaps most of what can be understood within this perspective has already been elucidated. If so, future advances will require that neuroscience become more physics-like with regard to reliance on abstract concepts and mathematical description. It is interesting to note that at least two recent developments regarding the operation of the nervous system, the discovery of the human magnetic sense (Carrubba *et al.*, 2007) and an explanation of the basis for memory formation (Lin *et al.*, 2007; Lin *et al.*, 2005; Lin, Osan and Tsien, 2006), were based explicitly on the notion that the phenomena studied were nonlinear in nature. The hallmark of both experimental approaches was the reliance on abstract concepts and mathematical analysis and the avoidance of analytical techniques that amount to averaging away the phenomenon of interest. We expect that further advances will be made when this approach is followed in the context of other problems associated with the nervous system.

Glossary

Action potential: a self-propagating electrical signal initiated in a neuron when the membrane potential in a localized area of the cell membrane becomes depolarized beyond a threshold value.

Antidromic action potential: movement of an action potential in a direction opposite to that of normal propagation. Back-propagation.

Axon: the neuronal process that transmits the action potential from the cell body to the synapse.

Back-propagation algorithm: an iterative mathematical procedure for training an artificial neural network.

Connexin: protein subunit of a gap junction.

Delayed rectifier: an axonal K^+ channel that opens with depolarization and is largely responsible for repolarizing the axon membrane following an action potential.

Dendrites: branches that extend from the neuronal cell body and function to receive messages from other neurons.

Dendritic spines: narrow projections from dendrites present on many types of neurons; they can be the locus of synaptic inputs.

Direct chemical synapse: a synapse in which neurotransmitter molecules bind to ionotropic receptors (ion channels) in the postsynaptic membrane. The binding produces a conformational change in the receptor, thereby allowing ions to flow in or out of the cell, resulting in a change of membrane potential.

Electroencephalogram (EEG): a spontaneous nonstationary electrical signal consisting of the sum of the action potentials and synaptic potentials occurring throughout the brain.

Electrotonus: passive spread of electrical potential; occurs in the neuronal membrane.

Evoked potential: an electrical potential recorded on the scalp following

presentation of a sensory stimulus to the subject (to be distinguished from the electroencephalogram, which is a spontaneous electrical potential).

Gap junctions: ion channels that connect the cytoplasm of adjacent cells, thereby allowing ions and small signaling molecules to pass between the cells.

Gating current: the movement of electrical charge in voltage-gated channels, which occurs during formation of a transmembrane ion pore.

Hillock: location in a neuron where the action potential is initiated.

Indirect chemical synapse: a synapse in which neurotransmitter molecules bind to receptors in the postsynaptic membrane, leading to activation of a second-messenger signaling system (usually G proteins). The messenger molecules open ion channels thereby allowing ions to flow in or out of the cell, resulting in a change in membrane potential.

Ion channels: transmembrane proteins that allow ions to pass through the cell membrane.

Ligand-gated channels: ion channels whose conductance depends directly or indirectly on the binding of a neurotransmitter to the channel.

Long-term memory: information storage in the nervous system that causes a permanent change in synaptic patterns.

Membrane potential: electrical potential of the cell interior relative to the cell bath.

Memory: accessible storage of information in the brain.

Neuron: the electrically active cell of the nervous system.

Neurotransmitter: a chemical agent synthesized and secreted by a presynaptic

cell that effects a communication with a postsynaptic cell.

Plasticity: the tendency of synapses and neural circuits to change as a result of activity.

Receptor potential: initial response of a receptor cell to a stimulus, consisting of a change in voltage across the receptor membrane.

Receptors: cells that directly transduce a chemical, mechanical, or energetic stimulus to produce the receptor potential.

Recurrence analysis: a mathematical technique for detecting nonlinear deterministic activity in a time series such as a biological signal.

Resting membrane potential: the membrane potential under steady-state conditions (no net current or applied voltage).

Reversal potential: for a channel with one permeant ion, the equilibrium potential determined from the Nernst equation.

Selectivity: the permeant ion species of a channel pore.

Sensory receptor: a structure that recognizes a stimulus in the external or internal environment of an organism.

Short-term memory: information storage resulting in a temporary change in synaptic patterns.

Site-directed mutagenesis: a form of genetic engineering that permits changes in specific nucleic acids in a given gene.

Synapses: specialized junctions between neighboring neurons that facilitate transmission of signals between the cells.

Uptake carriers: membrane proteins that facilitate uptake or release of neurotransmitters, ions, and other substances.

Voltage-clamp: a technique for studying transmembrane ion kinetics in which

the membrane potential is held at a predetermined value.

Voltage-gated: ion channels whose conductance depends on the membrane potential.

Volume diffusion: a form of volume transmission in which neurotransmitters diffuse through the cerebrospinal fluid, thereby reaching distant receptors.

Volume transmission: information transfer within the nervous system by means other than a synapse.

References

- Atwell, D., Barbour, B., and Szatkowski, M. (1993) Nonvesicular release of neurotransmitters. *Neuron*, **11**, 401–7.
- Benarroch, E.E. (2007) Sodium channels and pain. *Neurology*, **68**, 233–36.
- Bjelke, B., England, R., Nicholson, C., Rice, M., Lindberg, J., Zoli, M., Agnati, L., and Fuxe, K. (1995) Long distance pathways of diffusion for dextran along fibre bundles in the brain. Relevance for volume transmission. *Neuroreport*, **6**, 1005–9.
- Bullock, T.H. (1997) Signals and signs in the nervous system: the dynamic anatomy of electrical activity is probably information rich. *Proc. Natl. Acad. Sci., U.S.A.*, **94**(1), 1–6.
- Bullock, T.H., Bennett, M.V., Johnston, D., Josephson, R., Marder, E., and Fields, R.D. (2005) Neuroscience. The neuron doctrine, redux. *Science*, **310**, 791–93.
- Carrubba, S., Frilot II, C., Chesson Jr, A.L., and Marino, A.A. (2007). Evidence of a nonlinear human magnetic sense. *Neuroscience*, **144**, 356–67.
- Deutsch, S. and Micheli-Tzanakou, E. (1987) *Neuroelectric Systems*, New York University Press, New York.
- Doyle, D.A., Morais, C.J., Pfuetzner, R.A., Kuo, A., Gulbis, J.M., Cohen, S.L., Chait, B.T., and MacKinnon, R. (1998) The structure of the potassium channel: molecular basis of K⁺ conduction and selectivity. *Science*, **280**, 69–77.
- Fesenko, E.E., Kolesnikov, S.S., and Lyubarsky, A.L. (1985) Induction by cyclic GMP of cationic conductance in plasma membrane of retinal rod outer segment. *Nature*, **313**, 310–13.
- Gouaux, E. and Mackinnon, R. (2005) Principles of selective ion transport in channels and pumps. *Science*, **310**, 1461–65.
- Hanson, P.I. and Schulman, H. (1992) Inhibitory autophosphorylation of multifunctional Ca²⁺/calmodulin-dependent protein kinase analyzed by site-directed mutagenesis. *J. Biol. Chem.*, **267**, 17216–17224.
- Hervé, J.C., Bourmeyster, N., Sarrouilhe, D., and Duffy, H.S. (2007) Gap junctional complexes: from partners to functions. *Prog. Biophys. Mol. Biol.*, **94**, 29–65.
- Hille, B. (1992) *Ionic channels of excitable membranes*, Sinauer, Sunderland MA.
- Hodgkin, A. and Huxley, A. (1952) A quantitative description of membrane current and its application to conduction and excitation in nerve. *J. Physiol.*, **117**, 500–44.
- Kachar, B., Parakkal, M., Kurc, M., Zhao, Y., and Gillespie, P.G. (2000) High-resolution structure of hair-cell tip links. *Proc. Natl. Acad. Sci., U.S.A.*, **97**, 13336–41.
- Kandel E.R., Schwartz J.H., and Jessell T.M. (eds) (2000). *Principles of Neural Science*, McGraw-Hill, New York.
- Kolomytkin, O.V., Dunn, S., Hart, F.X., Frilot, C., Kolomytkin, D., and Marino, A.A. (2007) Glycoproteins bound to ion channels mediate detection of electric fields: a proposed mechanism and supporting evidence. *Bioelectromagnetics*, **28**, 379–85.
- Lin, L., Chen, G., Kuang, H., Wang, D., and Tsien, J. (2007) Neural encoding of the concept of nest in the mouse brain. *Proc. Natl. Acad. Sci., U.S.A.*, **104**, 6066–71.
- Lin, L., Osan, R., Shoham, S., Jin, W., Zuo, W., and Tsien, J. (2005) Identification of network-level coding units for real-time representation of episodic experiences in the hippocampus. *Proc. Natl. Acad. Sci., U.S.A.*, **102**, 6125–30.
- Lin, L., Osan, R., and Tsien, J. (2006) Organizing principles of real-time memory encoding: neural clique assemblies in universal neural codes. *Trends Neurosci.*, **29**, 48–57.
- Magee, J.C. and Johnston, D. (1997) A synaptically controlled, associative signal for

- hebbian plasticity in hippocampal neurons. *Science*, **275**, 209–13.
- Markram, H., Lubke, J., Frotscher, M., and Sakmann, B. (1997) Regulation of synaptic efficacy by coincidence of postsynaptic APs and EPSPs. *Science*, **275**, 213–15.
- McKenna T., Davis J., and Zornetzer S.F. (eds) (1992). *Single Neuron Computation*, Academic Press, Boston.
- Nayak, A.S., Moore, C.I., and Browning, M.D. (1996) Ca^{2+} /calmodulin-dependent protein kinase II phosphorylate of the presynaptic protein synapsin I is persistently increased during long term potentiation. *Proc. Natl. Acad. Sci., U.S.A.*, **93**, 15451–56.
- Pastalkova, E., Serrano, P., Pinkhasova, D., Wallace, E., Fenton, A., and Sacktor, T. (2006) Storage of spatial information by the maintenance mechanism of LTP. *Science*, **313**, 1141–44.
- Rall, W. (1960) Membrane potential transients and membrane time constant of motoneurons. *Exp. Neurol.*, **2**, 503–32.
- Sejnowski, T.J. (1997) The year of the dendrite. *Science*, **275**, 178.
- Serrano, P., Yao, Y., and Sacktor, T. (2005) Persistent phosphorylation by protein kinase Mzeta maintains late-phase long-term potentiation. *J. Neurosci.*, **25**, 1979–84.
- Shepherd G.M. (ed) (1990). *The Synaptic Organization of the Brain*, Oxford Press, New York.
- Skinner, B.F. (1966) The phylogeny and ontogeny of behavior. Contingencies of reinforcement throw light on contingencies of survival in the evolution of behavior. *Science*, **153**, 1205–13.
- Sukharev, S. and Corey, D.P. (2004). Mechano-sensitive channels: multiplicity of families and gating paradigms. *Sci. STKE*, Feb. 3(219), re4.
- Suzuki, M., Morita, T., and Iwamoto, T. (2006) Diversity of Cl^{-} channels. *Cell. Mol. Life Sci.*, **63**, 12–24.
- Webber, C.L. and Zbilut Jr, J.P. (1994) Dynamical assessment of physiological systems and states using recurrence plot strategies. *J. Appl. Physiol.*, **76**, 965–73.

Further Reading

- Byrne J.H. and Roberts J.L. (eds) (2004). *From Molecules to Networks*, Elsevier, New York.
- Dayan, P. and Abbott, L.F. (2005). *Theoretical Neuroscience*, MIT Press, Cambridge.
- Izhikevich, E.M. (2007). *Dynamical Systems in Neuroscience*, MIT Press, Cambridge.
- Koch, C. (2004). *Biophysics of Computation*, Oxford University Press, New York.
- Niedermeyer, E. and Silva, F.L.d. (1999). *Electroencephalography: Basic Principles, Clinical Applications and Related Fields*, 4th edn, Urban and Schwarzenberg, Baltimore.
- Nunez P.L. and Srinivasan R. (eds) (2006). *Electric Fields in the Brain: The Neurophysics of EEG*, Oxford University Press, New York.
- Squire, L.R. and Kandel, E.R. (2000). *Memory: From Mind to Molecules*, Scientific American, New York.
- Yuste, R. and Tank, D.W. (1996). Dendritic integration in mammalian neurons, a century after Cajal. *Neuron*, **16**, 701–16.
- Zoli, M. and Agnati, L.F. (1996). Wiring and volume transmission in the central nervous system: The concept of closed and open synapses. *Prog. Neurobiol.*, **49**, 363–80.