

Laplace Plane Analysis of Impedance on the H Meridian

Maria Reichmanis, Ph.D., Andrew A. Marino, Ph.D. and Robert O. Becker, M.D.

*Department of Orthopedic Surgery, SUNY Upstate Medical Center, Syracuse, New York
and Veterans Administration Hospital, Syracuse, New York*

(Received for publication December 28, 1978)

Abstract: The AC impedance of a length of the H meridian not containing any acupuncture points was studied by means of Laplace plane analysis of the time domain response to an input voltage pulse. The ensuing frequency domain data were compared to the results of an identical analysis for two anatomically similar controls on either side of the meridian. The resistance of the meridian was significantly lower than either control.

WE HAVE STUDIED the AC electrical characteristics of acupuncture points in considerable detail (1-4). In one study we reported that the impedance between two such points could be represented by a passive equivalent circuit (1). The resistance between the points was lower than the resistance between two anatomically similar control points, and the capacitance was significantly higher. Inasmuch as the acupuncture points are believed to be located along channels called meridians, it was not possible to correlate the observed differences in R and C exclusively with either the acupuncture points or the meridians. We therefore undertook an analogous study of two non-acupuncture sites located along a meridian. The frequency dependence of the skin impedance was obtained, as before, by a Laplace transformation of the subject current resulting from a voltage pulse input in the time domain (1,5,6).

Method

After determining the positions of the acupuncture points H-3 and H-4 (7), two intervening non-acupuncture sites on the H (heart) meridian were located. The skin was cleaned with 90% ethanol followed by distilled water, and one-cm. diameter conducting-rubber electrodes (modified LIDC electrodes, Ritter Co.) were applied and connected to the voltage source. The input voltage $V(t)$, a pulse with a rise-time of 10 μsec , a duration of 100 μsec , and a maximum amplitude of 1.0 v was displayed on one channel of a dual-

LAPLACE PLANE ANALYSIS OF IMPEDANCE ON THE H MERIDIAN

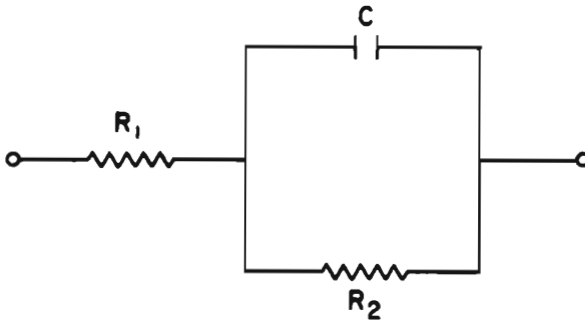

Figure 1. Equivalent circuit for AC skin impedance. This model, while not necessarily unique (9,10), is an adequate first-order linear approximation for the impedance of human skin in the frequency range DC to 1 MHz (1).

trace oscilloscope. The subject current $I(t)$ was shown on the second channel (1,5,6) and the display photographed for later analysis.

Two pairs of anatomically similar control points (located in areas supposedly devoid of meridian lines or acupuncture points) were treated in identical fashion. The relative positions of all the areas used in this study are shown in Figure 2. None were in locations containing cuts, abrasions, or pigmented moles.

This procedure was repeated on a total of 10 volunteer subjects concurrently with a similar series of recordings for the acupuncture points H-3 and H-4. While the subjects were informed in general terms of the purpose of the study, the actual nature of the areas tested was not disclosed.

Points defining the curves $V(t)$ and $I(t)$, taken from the photographs, were the input data for real and imaginary axis Laplace transformations for each individual subject (8). The program output included data on the frequency variation of the transient skin impedance and phase angle (DC to 1 MHz).

Results

All the frequency domain data resulting from the imaginary axis Laplace transformation were adequately described by the complex impedance function

$$Z(\omega) = R_1 + 1/(j\omega C + 1/R_2)$$

in the range DC to 1 MHz (1,5,6). The real axis Laplace transformation yielded an impedance function of the same form:

$$Z(\sigma) = R_1 + 1/(\sigma C + 1/R_2).$$

The model circuit elements R_1 , R_2 , and C could be found by examination of the appropriate low and high frequency limits of $Z(\sigma)$, $\text{Im}Z(\omega)$, and $\text{Re}Z(\sigma)$ (1,8-10).

The mean values of R_1 , R_2 , and C , together with the minimum phase angle ϕ_{min} , where $\tan\phi = \text{Im}Z(\omega)/\text{Re}Z(\omega)$, are given in Table I. Due to the wide variation in the magnitude of these parameters between individual subjects, the control data were normalized with respect to the meridian data for each subject before statistical analysis.

Analysis of variance (11) of the pooled, normalized data showed that there were no significant differences between subjects in any of these parameters. There were significant differences between the meridian and control point data in R_1 , R_2 , and C [$F(2,27) > 3.35$, $p < 0.05$].

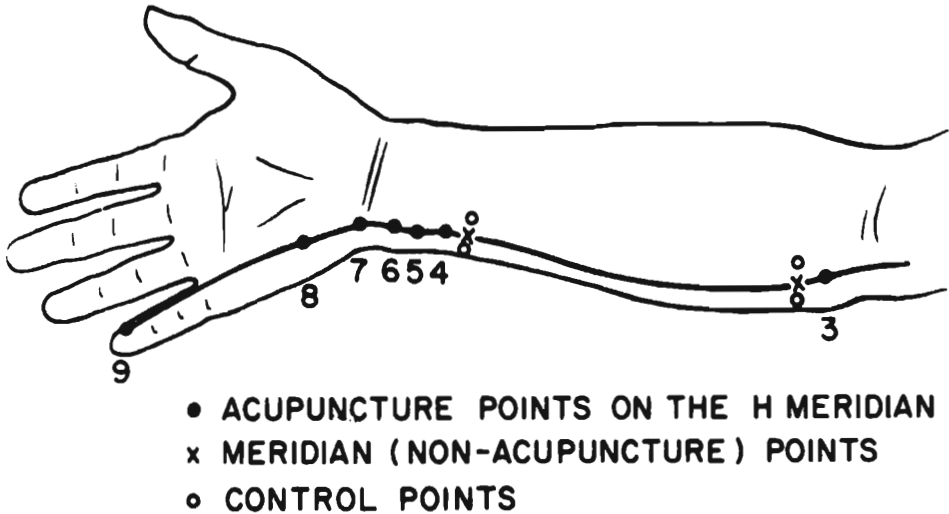

Figure 2. Acupuncture points on the H meridian, together with the meridian (non-acupuncture) and control sites used in this study. The meridian areas were $1\frac{1}{2}$ cm distal to H-3 and proximal to H-4. Their controls were $1\frac{1}{2}$ cm to either side.

We required that any experimental parameter be greater (or smaller) than both controls simultaneously before concluding that it was significantly different from the control values. This was necessary in order to mitigate the possible effects of any minor differences in surface anatomy between the experimental points and any single pair of control points (1,6). The utility of this criterion was demonstrated in the results for the equivalent capacitance C : the capacitance between the meridian sites was higher than between the controls, but only significantly higher than control 1 ($p < 0.05$, 2-tailed t-test). This particular result was therefore discounted. On the other hand, R_1 and R_2 were significantly lower between the meridian sites than between either pair of control areas. There were no significant differences in ϕ_{min} , which varied least between subjects of all the parameters (see Table I).

Conclusion

The resistive component (R_1 , R_2) of the skin impedance between two non-acupuncture sites on the H meridian was significantly lower than between two pairs of anatomically similar control points. There were no significant differences in the capacitance or phase angle. Thus, at least some meridians, as well as some acupuncture points (1) are distinguishable by means of their electrical properties.

This project was supported by a grant from the Hendricks Research Fund (Syracuse University), Grant No. GM-21847 from the National Institutes of Health, and the Veterans Administration Research Service, Project No. 0865.

LAPLACE PLANE ANALYSIS OF IMPEDANCE ON THE H MERIDIAN

TABLE I.
Mean Values of (A) R_1 , (B) R_2 , (C) C , and (D) ϕ_{min} for the group of 10 subjects

Table IA. R_1 ($K\Omega$).

Subject	Control 1	H Meridian	Control 2
1	148 ± 5	201 ± 17	264 ± 13
2	24.1 ± 5.0	12.0 ± 0.1	36.1 ± 3.5
3	18.8 ± 7.1	15.4 ± 1.6	17.8 ± 1.8
4	84.3 ± 2.6	5.77 ± 0.73	56.0 ± 1.5
5	45.2 ± 0.3	37.6 ± 3.0	36.0 ± 6.9
6	9.72 ± 0.88	30.9 ± 2.1	13.2 ± 0.6
7	11.2 ± 0.6	2.36 ± 0.13	15.2 ± 0.4
8	15.4 ± 0	10.9 ± 1.5	24.2 ± 2.1
9	6.36 ± 0.52	7.02 ± 0.18	6.15 ± 0.42
10	52.5 ± 0.8	4.69 ± 0.48	33.4 ± 0.8

Table IB. R_2 ($K\Omega$)

subject	Control 1	H Meridian	Control 2
1	18,200 ± 1,700	7,920 ± 954	10,500 ± 1,700
2	754 ± 217	528 ± 85	3,720 ± 1,240
3	303 ± 88	163 ± 8	1,190 ± 438
4	1,470 ± 115	197 ± 48	1,130 ± 5
5	2,210 ± 247	3,020 ± 194	857 ± 52
6	344 ± 149	1,340 ± 628	787 ± 1
7	472 ± 149	80.9 ± 11.7	1,033 ± 47
8	242 ± 6	167 ± 68	1,020 ± 204
9	240 ± 86	205 ± 23	202 ± 42
10	1,720 ± 230	179 ± 17	494 ± 27

M. REICHMANIS, A.A. MARINO AND R.O. BECKER

Table IC. C(pf).

Subject	Control 1	H Meridian	Control 2
1	8.35 ± 0.21	9.65 ± 0.07	4.87 ± 0.64
2	83.4 ± 27.7	81.0 ± 5.1	32.0 ± 0.3
3	176 ± 60	174 ± 2	126 ± 13
4	50.4 ± 1.8	161 ± 7	48.7 ± 2.8
5	68.9 ± 1.1	90.3 ± 4.0	62.5 ± 1.5
6	146 ± 20	75.0 ± 0	128 ± 1
7	117 ± 25	1,190 ± 55	74.2 ± 6.4
8	234 ± 4	640 ± 45	79.5 ± 6.5
9	337 ± 0	327 ± 2	298 ± 4
10	50.2 ± 2.1	395 ± 3	140 ± 3

Table ID. ϕ min (deg)

Subject	Control 1	H Meridian	Control 2
1	-79.6 ± 0.7	-72.1 ± 0.3	-72.0 ± 1.8
2	-69.8 ± 0.9	-72.9 ± 1.3	-78.4 ± 1.4
3	-63.3 ± 1.3	-57.3 ± 3.0	-75.6 ± 2.8
4	-63.7 ± 0.8	-70.3 ± 3.5	-65.5 ± 1.2
5	-73.8 ± 0.8	-74.9 ± 4.9	-67.5 ± 1.5
6	-71.2 ± 0.5	-71.6 ± 5.4	-75.4 ± 0.5
7	-72.1 ± 3.3	-70.8 ± 1.1	-76.3 ± 0.5
8	-62.5 ± 0.4	-56.2 ± 3.2	-72.5 ± 1.0
9	-71.0 ± 3.7	-69.4 ± 1.2	-70.2 ± 3.7
10	-70.4 ± 1.6	-71.8 ± 2.4	-61.6 ± 0.6

References

1. Reichmanis, M., A.A. Marino and R.O. Becker Laplace plane analysis of impedance between acupuncture points H-3 and H-4. *Comparative Med. East and West*, 5:289-295, 1977.
2. Reichmanis, M., A.A. Marino and R.O. Becker Electrical correlates of acupuncture points. *IEEE Trans. Biomed. Eng.*, BME-22:533-535, 1975
3. Reichmanis, M., A.A. Marino and R.O. Becker DC skin conductance variation at acupuncture loci. *Am. J. Chinese Med.*, 4:69-72, 1976.
4. Becker, R.O., M. Reichmanis, A.A. Marino and J.A. Spadaro Electrophysiological correlates of acupuncture points and meridians. *Psychoenergetic Systems*, 1:105-112, 1976.
5. Reichmanis, M., A.A. Marino and R.O. Becker Laplace plane analysis of skin impedance: a preliminary investigation. *J. Electrochem. Soc.*, 125:1765-1768, 1978.
6. Reichmanis, M., A.A. Marino and R.O. Becker Laplace analysis of transient impedance between acupuncture points Li-4 and Li-12. *IEEE Trans. Biomed. Eng.*, BME-24:402-405, 1977.
7. Dufour, R. *Atlas d'Acupuncture Topographique*. Paris: Le Francois, 1960, pp. 33-34.
8. Pilla, A.A. Laplace plane analysis of electrode kinetics. In *Computers in Chemistry and Instrumentation*, Vol. III (Electrochemistry). New York: Marcel Dekker, 1972, pp. 139-181.
9. Burton, C.E., R.M. David, W.M. Portnoy and L.A. Akers The application of Bode analysis of skin impedance. *Psychophysiology*, 11:517-524, 1974.
10. Van Valkenburg, M.E. *Network Analysis* (3rd edition). Englewood Cliffs, N.J.: Prentice-Hall, 1974.
11. Mendenhall, W. and R.L. Schaeffer *Mathematical Statistics With Applications*. N. Scituate, Mass.: Duxbury Press, 1973.
12. Informed consent was obtained from all volunteers participating in this study after the nature of the procedure had been explained.