

Laplace Plane Analysis of Impedance Between Acupuncture Points H-3 and H-4

MARIA REICHMANIS*, Ph.D.

*Upstate Medical Center Department of Orthopedic Surgery**

ANDREW A. MARINO*, Ph.D.

Department of Orthopedic Surgery

and Veterans Administration Hospital Syracuse, New York*

ROBERT O. BECKER*, M.D.

Veterans Administration Hospital

Received for publication September 20, 1977

The frequency dependence of the skin impedance between two acupuncture points (H-3 and H-4) was determined by Laplace plane analysis of the time domain response to an input voltage perturbation. Both the resistance and capacitance between the acupuncture points differed significantly from the corresponding controls, thus supporting the interpretation of the acupuncture system as an information transfer network

INTRODUCTION

We previously reported evidence to support the widely-held assumption that acupuncture points are local DC skin conductance maxima (resistance minima) with respect to a neutral reference [1-3]. Investigation of the AC impedance characteristics of acupuncture points can potentially yield more information than DC measurements. We therefore felt it desirable to proceed with such AC studies.

Rather than relying on cumbersome and time-consuming direct measurements of the variation of skin impedance with frequency, we studied the current resulting from a predetermined voltage perturbation in the time domain. The frequency dependence of the skin impedance was computed from the frequency domain functions corresponding to the input voltage $V(t)$ and the subject current $I(t)$, obtained by performing a Laplace transformation on the time domain data.

The Laplace transform $F(s)$ of some time domain function $f(t)$ is defined as:

$$F(s) = \int_0^{\infty} f(t)\exp(-st)dt,$$

where $s = \sigma + j\omega$ defines the complex frequency plane with real axis σ and imaginary axis $j\omega$. The integration can be carried out along either axis. Consider the real axis σ , we find that

$$F(\sigma) = \int_0^{\infty} f(t)\exp(-\sigma t)dt, \sigma > 0$$

If we perform this integration on both $V(t)$ and $I(t)$, we can define the real axis impedance of the system as

The American Journal of Chinese Medicine
P.O. Box 555, Garden City, New York 11530

$$Z(\sigma) = V(\sigma)/I(\sigma)$$

For the imaginary axis $j\omega$,

$$F(j\omega) = \int_0^{\infty} f(t)\exp(-j\omega t)dt$$

This imaginary axis transform is equivalent to a single-sided Fourier transform. The imaginary axis impedance is

$$Z(j\omega) = V(j\omega)/I(j\omega),$$

where $Z(j\omega)$ is a complex function with a real component $ReZ(\omega)$ and an imaginary component $ImZ(\omega)$ [4-6].

Pilla [4] has developed a FORTRAN program for both real and imaginary axis Laplace transformations, using as input data $V(t)$, an arbitrary voltage perturbation, and $I(t)$, the current response of the system under observation. The output data include $Z(\sigma)$, $ReZ(\omega)$, $ImZ(\omega)$, and the phase angle $\phi(\omega) = \tan^{-1} [ImZ(\omega)/ReZ(\omega)]$ as functions of frequency. All needed data on the time domain functions $V(t)$ and $I(t)$ could be obtained in a relatively short period of time. In addition, subsequent circuit analysis of the computed frequency domain functions necessitated no *a priori* assumptions about the form of the experimental impedance functions. This technique yields a passive equivalent circuit model for the AC impedance of the skin which is similar to a classic model obtained by more direct methods [4,7,8].

As an initial test of the applicability of the Laplace transform method to an investigation of the acupuncture system, we studied the impedance between points Li-4 and Li-12, which we had found to be significant DC resistance minima on most subjects [2]. The series resistance between these two acupuncture points was significantly lower than between anatomically similar control points [9]. In the present study, we examined two adjacent acupuncture points, thus eliminating the possible perturbing effects of intervening acupuncture points. These points were found to be significant resistance minima on most subjects by the previous criteria [2].

METHODS

The data were compiled as described earlier [9]. The input voltage $V(t)$, a pulse with a rise-time of 10 μ sec, a duration of 100 μ sec and a maximum amplitude of 1.0V was displayed on one channel of a dual-trace oscilloscope. The voltage across a small series resistor, proportional to the subject current $I(t)$, was shown on the second channel (see Fig. 1). Points defining the curves $V(t)$ and $I(t)$, taken from photographs of the display, were the input for a FORTRAN numerical integration program for real and imaginary axis Laplace transformations [4]. The program output included

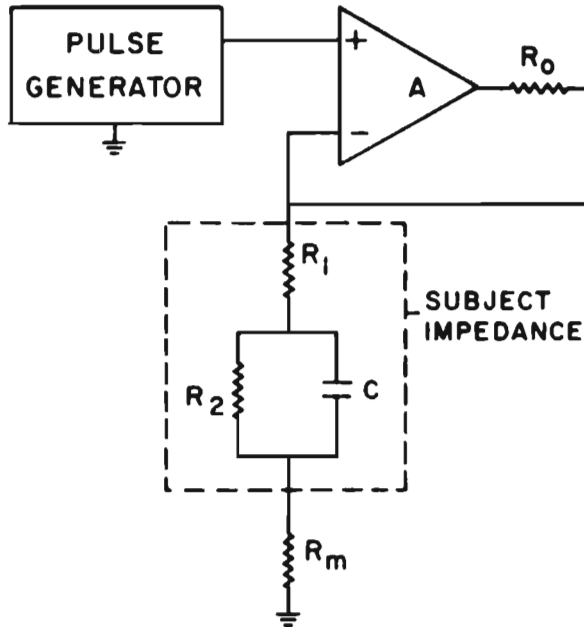

FIG. 1. The output $V(t)$ of a Tacussel model PRT-20-010-MOD potentiostat with output impedance R_o , controlled by a model GSTP-10 function generator, was applied to the subject. $V(t)$ was displayed on one channel of a dual-trace oscilloscope (Tektronix 564); the subject current $I(t)$, proportional to the voltage across a small series resistor R_m , was shown on the second channel. The subject is represented by a 3-element equivalent circuit which could have yielded the computed frequency domain response [8]. While not necessarily a unique representation of the subject impedance [5,11], this model is an adequate first-order linear approximation in the frequency range DC to 1 MHz.

the phase angle and real and imaginary components of the complex impedance as functions of frequency (DC to 1 MHz).

Acupuncture points H-3 and H-4 were located by means of standard charts [10]. One-centimeter diameter carbon-impregnated conducting-rubber electrodes (modified IDC electrodes, Ritter Co.) were applied to the skin after it had been cleansed with 90% ethanol followed by distilled water. The electrodes were connected to the voltage source and the ensuing oscilloscope display was photographed for later analysis. We found that several photographs at sweep speeds ranging from 0.5 $\mu\text{sec/cm}$ to 10 $\mu\text{sec/cm}$ were needed to obtain sufficient data for accurate mathematical analysis. Two pairs of anatomically similar control points, one set 1- $\frac{1}{2}$ cm ventral and the other 1- $\frac{1}{2}$ cm dorsal to the acupuncture points (Fig. 2), with the same separation, were treated identically. As we have noted before, two controls were needed in order to account for any spurious effects due to minor anatomical differences between the acupuncture points and any one pair of control points [9]. All of the points tested were in areas devoid of cuts, abrasions, and pigmented moles, with no apparent gross variations in skin texture. The subject was informed in general terms of the purpose of the study, but not of the actual nature of the points used. The procedure was repeated on a total of 10 volunteer subjects.

RESULTS

Bode analysis [5,11] established that the frequency domain data resulting from the real axis Laplace transformation could be adequately described for all 10 subjects by the impedance function

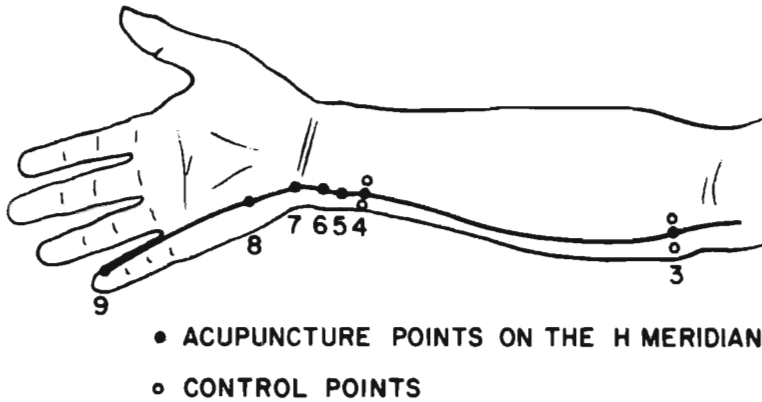

FIG. 2. Acupuncture points on the H meridian. The points (o) 1-1/2 cm. ventral to H-3 and H-4 were designated Control 1; two points on the same distance on the dorsal side of H-3 and H-4 were Control 2.

$$Z(\sigma) = R_1 + 1/(\sigma C + 1/R_2)$$

in the experimental range (DC to 1 MHz). The impedance function yielded by the imaginary axis transformation was of the same form with real and imaginary components

$$\text{Re}Z(\omega) = R_1 + 1/(\omega^2 C^2 + 1/R_2^2),$$

$$\text{Im}Z(\omega) = -\omega C/(\omega^2 C^2 + 1/R_2^2),$$

and a phase angle

$$\phi(\omega) = \tan^{-1} [\text{Im}Z(\omega)/\text{Re}Z(\omega)].$$

The constants could be derived from the low ($R_2\omega C \ll 1$) and high ($R_2\omega C \gg 1$) frequency limits of these functions (Table I). The mean values of R_1 , R_2 , C , and the minimum phase angle ϕ_{min} for each subject are listed in Table II. Because of the considerable variation between subjects in this data, the individual control data were normalized with respect to the acupuncture point data for statistical analysis.

Analysis of variance [12] of the pooled, normalized data indicated that there were no significant differences between subjects in any of these four parameters (R_1 , R_2 , C , ϕ_{min}). There were, however, significant differences between the acupuncture and control points in R_1 , R_2 , and C [$F(2,27) > 3.35, p < 0.05$]. Examination of the mean differences between groups showed that R_1 and R_2 were lower between acupuncture points H-3 and H-4 than between either pair of control points ($p < 0.05$, 2-tailed t-test). In addition, C was higher between the acupuncture points than between the

TABLE I
Low ($R_2\omega C \ll 1$) and high ($R_2\omega C \gg 1$) frequency limits
of $Z(\sigma)$, $ReZ(\omega)$, $ImZ(\omega)$, and $\tan \phi(\omega)$.^a

	$R_2\omega C \ll 1$	$R_2\omega C \gg 1$
$Z(\sigma)$	$R_1 + R_2$	$R_1 + 1/\sigma C$
$ReZ(\omega)$	$R_1 + R_2$	$R_1 + 1/R_2\omega^2 C^2$
$ImZ(\omega)$	$-\omega CR_2^2$	$-1/\omega C$
$\tan \phi(\omega)$	$-\omega CR_2^2/(R_1 + R_2)$	$-1/\omega CR_1$

^aThe constants R_1 , R_2 , and C could be derived from these limits. For example, $ImZ(\omega)$ vs. ω is a straight line with intercept zero and slope $-CR_2^2$ at low frequencies, and $ImZ(\omega)$ vs. $1/\omega$ is a line with slope $-1/C$ at high frequencies.

TABLE II
Mean and standard deviation of (A) R_1 , (B) R_2 , (C) C ,
and (D) ϕ_{min} for the group of 10 subjects.

A. $R_1(k\Omega)$			
Subject	Control	H-3 to H-4	Control 2
1	3.15 ± 0.04	1.22 ± 0.15	22.5 ± 0.5
2	77.8 ± 1.5	12.7 ± 2.1	74.0 ± 7.6
3	26.6 ± 2.8	11.9 ± 0.6	39.9 ± 1.8
4	38.2 ± 6.2	7.31 ± 1.3	48.5 ± 5.8
5	54.7 ± 1.5	8.32 ± 1.52	66.4 ± 3.0
6	131 ± 10	30.5 ± 8.7	80.8 ± 0.2
7	26.9 ± 0.1	3.58 ± 0	7.93 ± 0.29
8	16.2 ± 1.6	2.20 ± 0.13	181 ± 3
9	15.3 ± 0.1	4.67 ± 1.65	25.8 ± 2.6
10	58.4 ± 0.1	3.65 ± 0.07	9.60 ± 3.61

B. $R_2(K\Omega)$			
Subject	Control 1	H-3 to H-4	Control 2
1	65.9 ± 2.3	43.1 ± 5.0	172 ± 28
2	2,170 ± 250	753 ± 480	1,430 ± 505
3	2,060 ± 420	551 ± 62	458 ± 1
4	1,215 ± 5	308 ± 50	802 ± 267
5	1,890 ± 270	779 ± 45	4,440 ± 505
6	1,420 ± 110	1,740 ± 239	3,590 ± 335
7	1,720 ± 749	212 ± 34	3,990 ± 0
8	130 ± 23	79.5 ± 1.8	874 ± 52
9	595 ± 190	126 ± 14	1,640 ± 330
10	1,370 ± 0	114 ± 7	391 ± 2

controls. We required that a parameter be significantly greater (or smaller) with respect to both controls simultaneously in order to mitigate against the possible effects of minor differences in anatomy between the acupuncture points and any one pair of control points [9]. There were no significant differences between the experimental and control data for ϕ_{min} , which exhibited relatively little variation between subjects (see Table IID).

TABLE II--continued

C. $C(pf)$

Subject	Control 1	H-3 to H-4	Control 2
1	2,100 \pm 55	1,920 \pm 280	281 \pm 15
2	34.2 \pm 1.6	105 \pm 18	41.1 \pm 3.2
3	92.3 \pm 2.0	208 \pm 6	61.9 \pm 1.1
4	122 \pm 31	257 \pm 3	84.7 \pm 5.4
5	57.5 \pm 0.9	121 \pm 2	44.3 \pm 0.9
6	32.5 \pm 0.4	76.2 \pm 0.7	81.2 \pm 0.5
7	82.4 \pm 0.8	65.0 \pm 0.1	133 \pm 1
8	516 \pm 111	858 \pm 72	622 \pm 119
9	166 \pm 13	775 \pm 4	62.6 \pm 8.5
10	58.1 \pm 2.7	507 \pm 20	272 \pm 27

D. $\phi_{max}(deg.)$

Subject	Control 1	H-3 to H-4	Control 2
1	-65.9 \pm 0.3	-71.2 \pm 0.1	-52.2 \pm 2.9
2	-68.9 \pm 1.9	-60.9 \pm 7.1	-63.7 \pm 5.7
3	-76.9 \pm 2.0	-73.5 \pm 0.6	-58.4 \pm 0.6
4	-70.3 \pm 1.6	-72.5 \pm 2.9	-69.9 \pm 2.1
5	-70.9 \pm 1.5	-78.4 \pm 0.8	-76.1 \pm 1.6
6	-57.6 \pm 0.1	-75.0 \pm 4.4	-73.1 \pm 1.1
7	-74.8 \pm 3.4	-75.2 \pm 1.2	-79.4 \pm 5.6
8	-52.9 \pm 4.2	-71.4 \pm 0.8	-44.0 \pm 0.7
9	-71.4 \pm 3.0	-68.8 \pm 4.8	-75.7 \pm 0.7
10	-67.2 \pm 0.1	-70.0 \pm 0.4	-72.6 \pm 1.4

CONCLUSION

Laplace plane analysis of the AC impedance between acupuncture points H-3 and H-4 established that the resistance (R_1 , R_2) was lower, and the capacitance (C) higher, than between either of two pairs of anatomically similar control points.

These results reinforce our previous work on the impedance between acupuncture points (Li-4 and Li-12) [9]. Unlike our earlier report, however, the configuration of the acupuncture points in this study was such that any possible perturbing effects of intervening points was excluded. While considerably more data would be required for any definitive conclusion, it appears likely that the AC impedance as well as the DC resistance of some acupuncture points is significantly different from that of other points on the skin and tend to support our interpretation of the classical acupuncture system as a network for information transmission [1,13,14].

ACKNOWLEDGEMENTS

This project was supported by a grant from the Hendricks Research Fund (Syracuse University), Grant No. GM 21847 from the National Institutes of Health, and the Veterans Administration Research Service, Project No. 0865.

REFERENCES

1. Becker, R.O., Reichmanis, M., Marino, A.A., Spadaro, J.A. Electrophysiological correlates of acupuncture points and meridians. *Psychoenergetic Systems* 1:105-112, 1976.
2. Reichmanis, M., Marino, A.A., Becker, R.O. Electrical correlates of acupuncture points. *IEEE Trans. Biomed. Eng.* BME-22:533-535, 1975.
3. Reichmanis, M., Marino, A.A., Becker, R.O. DC skin conductance variation at acupuncture loci. *Am. J. Chin. Med.* 4:69-72, 1976.
4. Pilla, A.A. Laplace plane analysis of electrode kinetics. In J.S. Mattson et al. (Eds.), *Computers in Chemistry and Instrumentation*, Vol. III (Electrochemistry). New York: Marcel Dekker, 1972.
5. Van Valkenburg, M.E. *Network Analysis* (3rd edition). Englewood Cliffs, New Jersey: Prentice-Hall, 1974.
6. Morse, P.M., Feshbach, H. *Methods of Theoretical Physics*. New York: McGraw-Hill Book Co., 1953.
7. Reichmanis, M. Laplace plane analysis of skin impedance. Presented at the 151st Meeting of the Electrochemical Society, Philadelphia, May 1977.
8. Edelberg, R. Electrical properties of the skin. In H.R. Elden (Ed.), *Biophysical Properties of the Skin*. New York: John Wiley and Sons, Inc., 1971.
9. Reichmanis, M., Marino, A.A., Becker, R.O. Laplace plane analysis of transient impedance between acupuncture points Li-4 and Li-12. *IEEE Trans. Biomed. Eng.* BME-24:402-405, 1977.
10. Dufour, R. *Atlas d'Acupuncture Topographique*. Paris (France): Le Francois, 1960.
11. Burton, C.E., David, R.M., Portnoy, W.M., Akers, L.A. The application of Bode analysis to skin impedance. *Psychophysiology* 11:517-524, 1974.
12. Mendenhall, W., Sheaffer, R.L. *Mathematical Statistics With Applications*. North Scituate, Mass: Duxbury Press, 1973.
13. Becker, R.O. The significance of bioelectric potentials. *Bioelectrochem. Bioenergetics* 1:187-199, 1974.
14. Becker, R.O. The basic biological data transmission and control system influenced by electrical forces. *Ann. N.Y. Acad. Sci.* 238:236-241, 1974.
15. Informed consent was obtained from all of the volunteers participating in this study after the nature of the procedure had been explained.